

論 文

적응형 필터링에 의한 NTSC 칼라 TV 신호의 성분분리의 개선

準會員 李 在 熙* 正會員 姜 哲 豪**

Improvement of Component Separation of NTSC Color TV Signals by Adaptive Filtering

Jae Hee LEE*, Cheol Ho KANG** *Regular Members*

要 約 본 논문에서는 NTSC 칼라 TV 합성신호를 프레임내에서 색도신호와 명도신호성분으로 분리하기 위한 두 종류의 적응 필터링 방식을 제시하였다. 적응 필터링 방식에 있어서 합성신호는 수직필터와 수평필터에 의하여 필터링 되어 지고 화상의 국부적인 특성에 따라 필터의 출력이 선택되어 진다. 첫번째 방식에서는 조건형 스위칭 알고리즘에 의하여 수직필터 또는 수평 필터의 출력이 최종단의 출력으로 결정되어 진다. 두번째 방식에서는 선형 조합 검출 알고리즘에 의하여 수직필터와 수평필터 출력의 가중치합이 최종단의 출력이 된다. 사용된 필터들은 NTSC 칼라 TV 합성신호를 4 fsc 로 샘플한 경우에 대하여 설계되어졌다. 몇가지 정량적인 기준을 이용하여 여러가지 방식들을 컴퓨터 시뮬레이션에 의하여 비교평가하였다.

ABSTRACT This paper represents two adaptive filtering methods for separating a composite NTSC Color TV signal in the frame into the luminance and chrominance components. In the adaptive filtering methods, the composite signal is filtered by the vertical filter and horizontal filter, and the output of the filters is selected dependent upon the local characteristics of the picture. In the first method, either the vertical or horizontal output is chosen to be the final output by conditional switching algorithm. In the second method, the weighted sum of the output of horizontal and vertical filters by linear combination detection algorithm becomes the final output. The filters are designed for NTSC Color TV signal. The various methods are compared using a number of quantitative

municate the time-varying sc
camera, which is a function
variables. Although it is nec
function and map it into a o
for transmission and display
signal remains three-dimens
cessing and transmission. It

J-
ar-

ate the composite TV signal into component signals in three-dimensions for digital interface which has been widely found in such applications as predictive coding technique,⁽¹⁾⁽²⁾ digital TV⁽³⁾ etc. Utilizing field or frame store unit, it will be possible to realize three-dimensional filters, which exploit special properties of PAL or NTSC signals for an efficient reduction of present disturbances such as cross-talk, noise and flicker effects. However, it has the following practical problems so far: it makes the circuits large and expensive and no adaptive three-dimensional filtering algorithms have been established. The cross-talk results from the process of component separation because the spectra of the luminance and chrominance signals are overlapped in the same frequency band and thus the signals cannot be separated exactly into the original components. The problem is to separate the signal with as few subjectively deteriorious effects as possible. The simple method of lumi-

nance/chrominance separation can be fulfilled by one-dimensional fixed filters such as luminance notch filter and chrominance band pass filter. The luminance notch suppresses subcarrier pattern in colored areas, but leaves residual cross-luminance on colored transmission in horizontal direction. On the other hand, the chrominance band-pass filter selects these luminance signals as colour information, giving cross-color patterns instead of fine black and white detail. To correct these defects, the method for removing the chrominance from luminance signal is with the band-limited comb filters.⁽⁴⁾⁽⁵⁾⁽⁶⁾ These filters pass frequencies near odd multiples of half the line frequency in the range of frequencies in which the chrominance information is expected to be found. The output of this filter is subtracted from the composite signal to obtain the luminance signal. The principal fault with this separation method as with other fixed techniques that are dependent on the average signal is that this

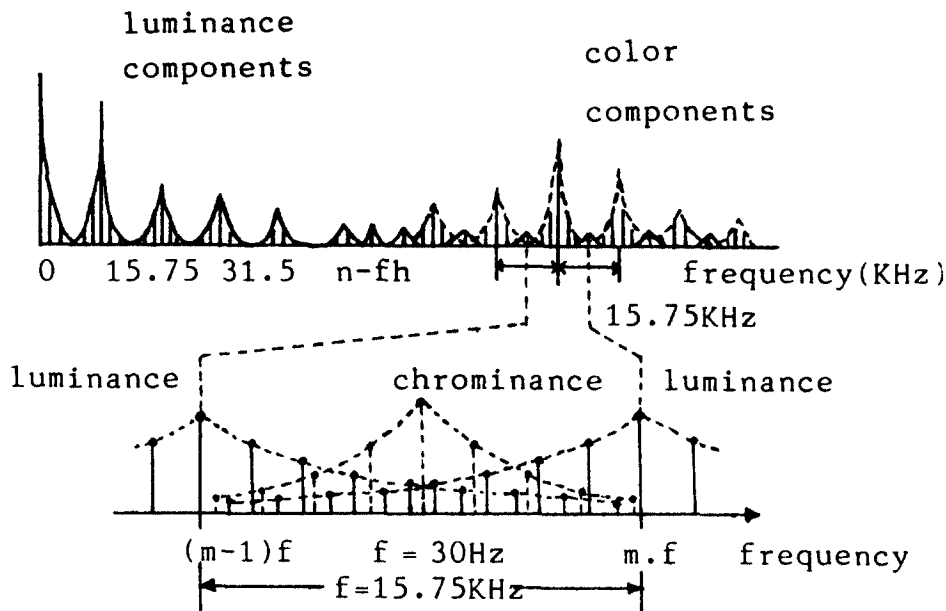

Fig. 1 The one-dimensional spectrum of NTSC COLOR TV signal

method introduces distortion in regions of the picture with characteristics different from the average picture characteristics. To overcome this difficulty, the conditional switching method has been studied that several fixed filters are selected and switched dependent upon the perceived characteristics in the local areas surrounding the composite samples to be separated.⁽⁷⁾⁽⁸⁾ But the principal fault with this separation method is that it occasionally results in the error in the luminance oscillating and producing dots in the image.⁽⁷⁾ In this paper, to improve the performance of component separation, two algorithms have been proposed by conditional switching and linear combination for detecting the local characteristics of the picture. The proposed algorithms have been verified by computer simulation for the CCITT standard color images.

II. THREE-DIMENSIONAL LATTICE DATA ARRAY

Any image transmission system requires an initial sampling and reformatting operation which converts the original signal, a function of

three-dimensional signal (space and time), into a one dimensional signal suitable for transmission over a communication channel. One dimensional spectrum of NTSC COLOR TV signal is illustrated in Fig. 1.⁽⁹⁾

As shown in Fig.1, the luminance and chrominance information are transmitted in the same frequency band. In conventional analog television, the sampling is carried out in two dimensions (only vertical and temporal) by means of interlaced scanning. In digital processing and transmission system, a full three dimensional sampling is required. The three dimensional spectrum is illustrated in Fig.2.⁽¹⁰⁾

In this section, the three dimensional data array which is sampled at four times the sub-carrier frequency will be discussed with stress on the relationship between the sampled point and the color signal phase. In the NTSC system, the chrominance signal C is modulated by the color difference signal I and Q. It is given by the following equation:

$$C(t) = I(t) \cos(2\pi f_{sc} * t) + Q(t) \sin(2\pi f_{sc} * t) \tag{1}$$

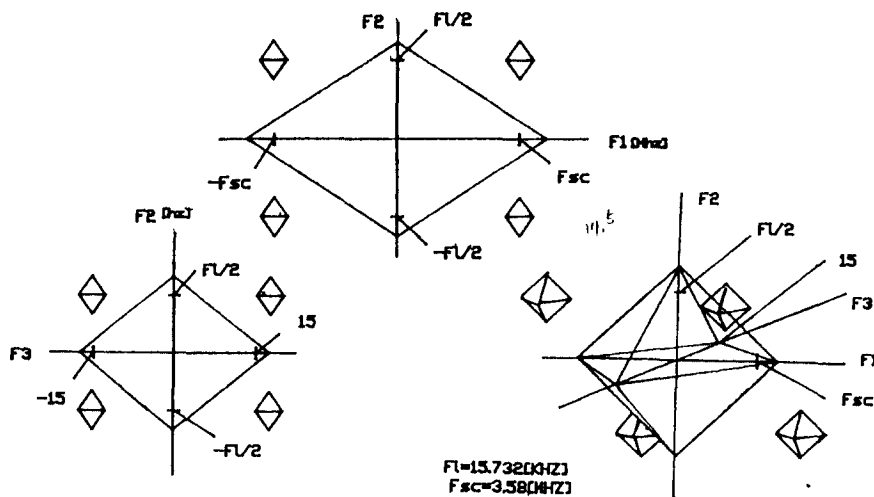

Fig. 2 The three-dimensional spectrum of NTSC COLOR TV signal

Here f_{sc} is the color subcarrier frequency determined as follows:

$$f_{sc} = 455 f_H / 2 \quad (f_H = 15.734 \text{ KHZ})$$

The composite signal U consists of chrominance C and luminance Y , i.e. $U(t) = Y(t) + C(t)$. At $4f_{sc}$ sampling rate for NTSC TV signal, the sampled data $U(n)$ is described as follows:

$$U(n) = Y(n) + I(n) \cos(n\pi/2) + Q(n) \sin(n\pi/2) \quad (2)$$

For $n=1$, $U(1) = Y(1) + Q(1)$, for $n=2$, $U(2) = Y(2) - I(2)$, for $n=3$, $U(3) = Y(3) - Q(3)$, for $n=4$, $U(4) = Y(4) + I(4)$ etc. The frequency of the color subcarrier f_{sc} is an odd multiple of $f_l/2$ and $f_r/2$ (f_l is the line frequency and f_r is the frame frequency) so that the phase of subcarrier changes by π from line to line and from frame to frame. The sampled three-dimensional data array is shown in Fig.3.

III. FILTER'S CONFIGURATION AND MAGNITUDE FREQUENCY RESPONSES

The filters used in the component separation consist of the vertical combfilter and horizontal comb filter. They are all finite impulse response (FIR) digital filters with linear phase for intra-frame processing.

1. Vertical comb filter

Vertical comb filter is composed of 2-line memory. The chrominance can be derived by difference from the mean value of upper and lower samples in the vertical direction as follows:

As an example

$$\begin{aligned} C_8 &= -1/4 (S_3 - 2S_8 + S_{13}) \\ &= -1/4 \{ (Y-Q) - 2(Y+Q) + (Y+Q) \} \\ &= Q \end{aligned} \quad (3)$$

The output of vertical filter is described by eq.(4).

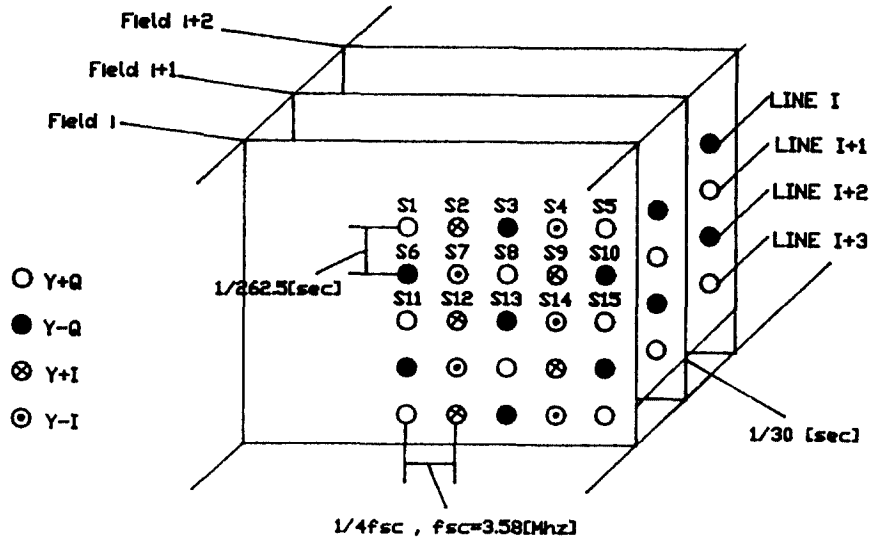

Fig. 3 Three-dimensional data array

$$V_0 = -1/4 \{ X(h, v-1/262.5, t) - 2X(h, v, t) + X(h, v+1/262.5, t) \} \quad (4)$$

The Z-transform of V_0 , $H(Z)$ is equal to eq.(5).

$$H(Z) = -1/4 (Z^{-1} - 2 + Z^1) \quad (5)$$

Thus, the frequency response of vertical comb filter is as following equation:

$$\begin{aligned} H(e^{j\omega t}) &= -1/4 (e^{-j\omega t T_v} - 2 + e^{j\omega t T_v}) \\ &= \sin^2(W T_v) \\ &= \sin^2(\pi * f / F_v) \end{aligned} \quad (6)$$

where

$$F_v = 262.5[\text{hz}], \quad T_v = 1 / (2 F_v) [\text{sec}] \quad (7)$$

The magnitude frequency response and simplified configuration of vertical comb filter are given in Fig.4.

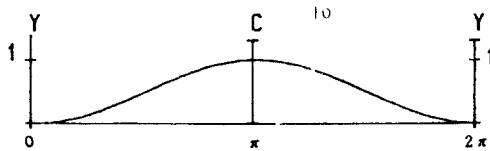

2. Horizontal comb filter

Horizontal comb filter is composed of 4-samples memory. The chrominance component can be derived by difference of the mean value between 2-delayed samples in the horizontal direction as shown in Fig.3.

As an example

$$\begin{aligned} C_8 &= -1/4 (S_6 - 2S_8 + S_{10}) \\ &= -1/4 \{ (Y-Q) - 2(Y+Q) + (Y-Q) \} \\ &= -Q \end{aligned} \quad (8)$$

The output of horizontal filter is described by eq. (9).

$$H_0 = -1/4 \{ X(h-1/2 f_{sc}, v, t) - 2X(h, v, t) + X(h+1/2 f_{sc}, v, t) \} \quad (9)$$

The frequency response of horizontal comb filter is defined by $H(e^{j\omega T})$

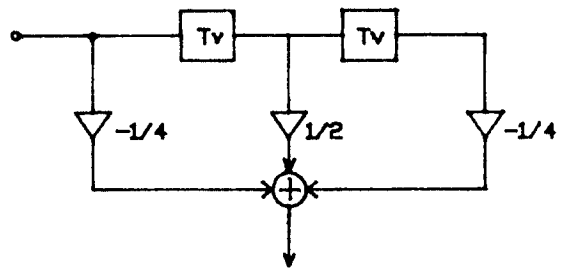

Fig. 4 (a) magnitude of frequency response
(b) simplified configuration

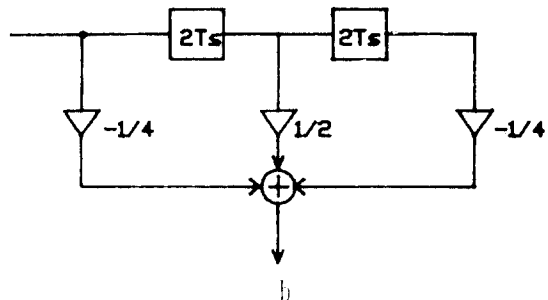
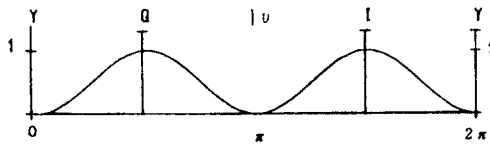

Fig. 5 (a) magnitude of frequency response
(b) simplified configuration

$$\begin{aligned}
 H(e^{j\omega T}) &= -1/4(e^{-j\omega T S} - 2 + e^{j\omega T S}) \\
 &= \sin^2(\omega T S) \\
 &= \sin^2(\pi * f/2 F_{sc})
 \end{aligned}
 \tag{10}$$

where

$$F_{sc} = 3.58 [\text{Mhz}], \quad T_s = 1/4 F_{sc} [\text{sec}] \tag{11}$$

The magnitude frequency response and simplified configuration of horizontal filter are given by Fig.5.

IV. ADAPTIVE Y/C SEPARATION ALGORITHMS

As the luminance and chrominance components in NTSC Color TV signal are transmitted in the same frequency band in Fig.1. The resultant interleaving can't be separated perfectly by use of the conventional comb filters. There is a mutual leakage(cross-talk) between two components causing cross-luminance and cross-color interferences. This will result in impairment of the overall picture quality, especially in the active area of a picture content. To prevent from the cross-talk, an adaptive Y/C separation method is required. This method operates on the principle that the TV signal has an alternative correlation in the horizontal and vertical direction in the small areas. The adaptive Y/C separation method in intraframe can be described by Fig.6.

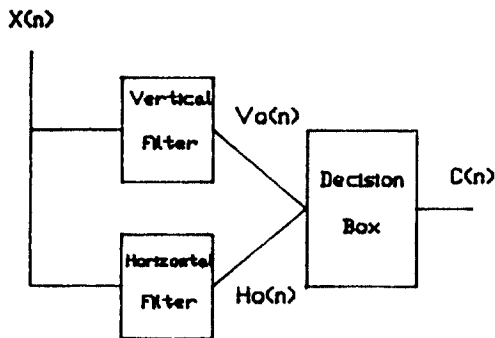

Fig. 6 The method of adaptive Y/C separation in intraframe

The design of the decision box shown in Fig.6 can be largely classified into conditional switching method and linear combination detection method. The first is a switching method which selects either horizontal comb filter or vertical one according to characteristics of the picture. The selection is done by choosing the filter of less change direction. The second is a linear combination method which uses the weighted sum of two filters' outputs by detecting the picture changes.

1. Conditional switching method

(1) Conventional algorithm

The conventional method is to determine whether the vertical or horizontal filter is to be used to separate the composite samples.⁽⁸⁾ It is necessary to detect less change in the picture either in the horizontal or in the vertical direction. A picture change is detected by comparing the difference between two adjacent samples. If there is a rapid change in the horizontal direction, the vertical comb filter operating on S3, S8, S13 is selected. Otherwise, the horizontal comb filter is selected. Let Hd and Vd denote the horizontal and the vertical difference by the following equality, i.e.:

$$H_d = |1 - Z^{-1}|, \quad V_d = |1 - W^{-1}|$$

where Z is one sample delay and W is one line delay.

$$\text{IF } V_d(n) < H_d(n) + K, \quad K : \text{constant} \tag{12}$$

$$\begin{aligned}
 \text{THEN } &V_o(n) = C_o(n) \\
 \text{ELSE } &H_o(n) = C_o(n) \\
 &Y_o(n) = X(n) - C_o(n)
 \end{aligned}
 \tag{13}$$

Here X(n), C_o(n), Y_o(n) are composite,

chrominance, luminance signal.

In this paper, other conditional switching algorithm has been proposed as the alternative method for the conventional one.

(2) Proposed algorithm A

In this algorithm the condition for selecting the horizontal comb filter or vertical one is different from the inequality (12). The criterion of this algorithm is the closeness of the separated components, H_o or V_o to the previous ones. The selection is based upon the less difference between in the horizontal and vertical direction. The algorithms A is as follows:

$$\begin{aligned}
 &\text{IF } |H_o(n) - H_o(n-1)| < |V_o(n) - V_o(n-1)| \\
 &\quad \text{THEN } V_o(n) = C_o(n) \\
 &\quad \text{ELSE } H_o(n) = C_o(n) \\
 &\quad \quad Y_o(n) = X(n) - C_o(n)
 \end{aligned} \tag{14}$$

The block diagram of algorithm A is given by Fig.7.

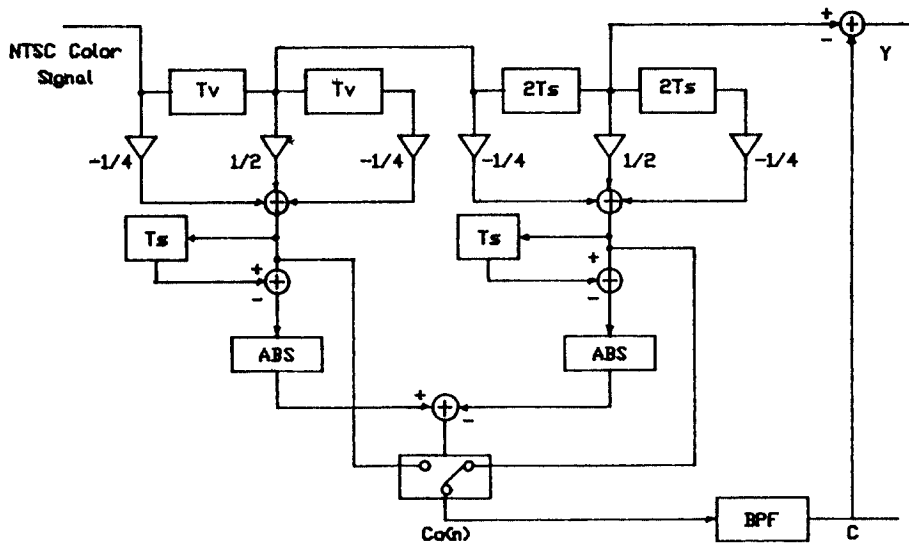

Fig. 7 The block diagram of algorithm A

The defect of switching method is that if the picture change occurs in the horizontal and vertical direction simultaneously, or the difference of change in both direction is very small, or the change of one direction is always less than that of the other direction, the conditional switching method is operated only on the direction where the picture change is less than others. This method results in ignoring the change in the other direction. Thus, the performance of this method is equal to that of band-limited comb filters.⁽⁶⁾ In this paper to correct this defect, a new adaptive algorithm has been proposed to combine the outputs of both filters adaptively dependent on the picture change. This operation can be performed by detecting the amount of change in both directions. This proposed adaptive Y/C separation method introduces the detection theory to resolve these problems.

2. Linear combination detection method

(1) Proposed algorithm B

In this algorithm the adaptation to the pic-

ture change is realized by introducing a detection coefficient α ($0 \leq \alpha \leq 1$). The algorithm B uses the linear combination which is made by the output of the vertical and horizontal filter according to the detection coefficient α as follows:

$$C(n) = \alpha H_o(n) + (1 - \alpha) V_o(n), \quad (0 \leq \alpha \leq 1) \quad (15)$$

To detect the coefficient α is carried out by subtracting two succeeding vertical line samples from each other, thereby forming the difference as the following eq.(16). The coefficient α is corresponding to the magnitude of frequency response of detector. As an example, the detection signal for the 8-th sample in Fig.3.

$$D_8 = |(S_{13} - S_3) / 2| \quad (16)$$

The output of detector is described by eq.(17).

$$D_o = |1/2 | X(h, v+1/262.5, t) - X(h, v-1/262.5, t) | \quad (17)$$

The Z-transform of D_o , $D(Z)$ is equal to eq.(18).

$$D(Z) = |1/2 (1 - Z^{-2})| \quad (18)$$

The frequency response of detector is given as eq.(19).

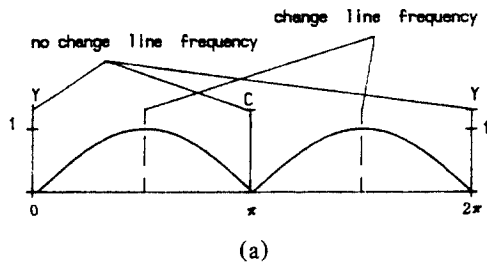

$$H(e^{j\omega T}) = |1/2 (1 - e^{-j\omega 4T})| = |\sin(\omega/2F_v)| \quad (19)$$

The magnitude frequency response and configuration of detector are shown in Fig.8.

Forming the difference of two successive lines results in zeros of the magnitude frequency response on multiples of line frequency in Fig.8 (a), indicating that the output of this filter is only zero for no change in vertical direction. If there is a change in vertical direction, additional frequency lines arise between these multiples of picture of lines frequency with a distance depending on quantity of change. These lines fall into the passband of the filter giving significant output value. An important attribute of this algorithm is to recognize the picture change by considering the sinusoidal passband characteristics in Fig.8 (a). When the picture change is only in horizontal direction, α decreases to zero. When the picture change is only in vertical direction, α increases to one. To realize the algorithm B in hardware, there needs two multipliers. Thus, the number of multiplier can be reduced by modifying this algorithm B as follows:

$$C_o(n) = \alpha (H_o(n) - V_o(n)) + V_o(n) \quad (20)$$

Detection configuration can share a common 2-line memory with the vertical comb filter,

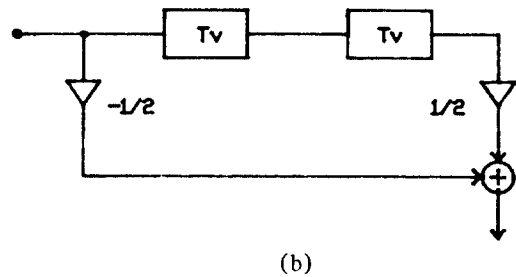

Fig. 8 (a) magnitude of frequency response
(b) simplified configuration

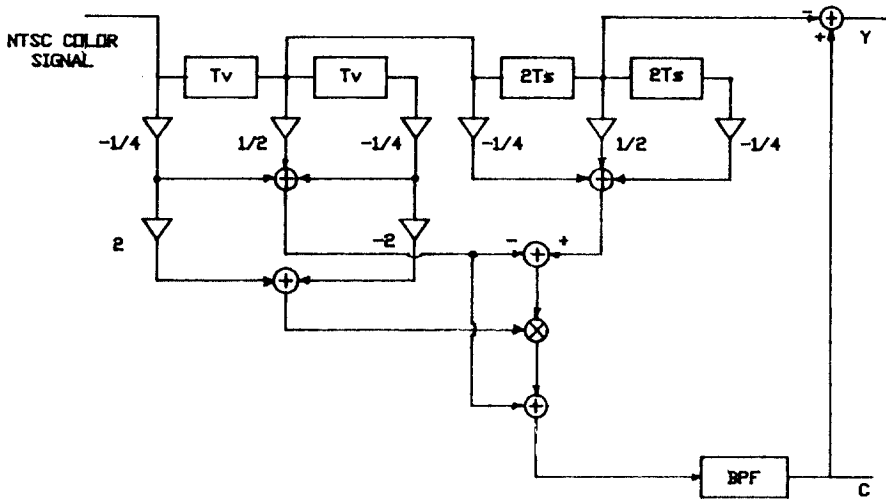

Fig. 9 The block diagram of algorithm B

which may be cost-effective for hardware implementation. The block diagram of algorithm B is shown in Fig.9.

Fig.9 illustrates the parallel implementation of the vertical and horizontal comb filter for delay equalization in which the middle tap of the line delay is provided as the input of sample delay element. The middle tap of four sample delay is again used as an appropriate delay point for the composite signal. And the luminance filter action is obtained by a subtraction of the chrominance filter output from the delayed composite signal.

One of the main advantages of this complementary realization is that only one additional band-pass filter is needed for the chrominance filter output. The band-pass filtering has the task of limiting the comb action to that frequency region in which crosstalk is likely to appear. As the comb filtering is only working in the subcarrier domain, low frequency components of the luminance remain unaltered. The magnitude frequency response of band-pass filter is shown in Fig.10.

V. THE RESULT OF SIMULATION AND EXAMINATION

In this section the results of computer simulation of the various separation methods are described. For the sake of comparison, a total of five methods have been selected. The method A uses only chrominance band-pass filter and luminance notch filter. The method B uses 2-line memory comb filter and chrominance band-pass filter.⁽⁶⁾ All of the remaining three methods use adaptive filters in horizontal and vertical direction. The method C is switching method

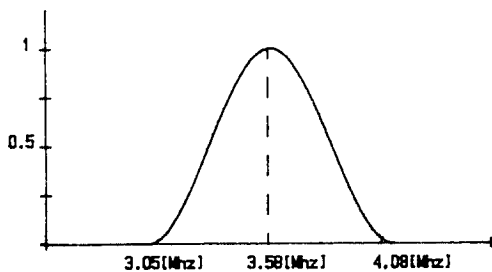

Fig.10 Magnitude frequency response of band pass filter

using the conventional switching algorithm.⁽⁸⁾ While the method D is to use the proposed algorithms A. The method E is using the proposed algorithm B. We used the Miss America and Checked Jacket of CCITT image data base to evaluate the performance of each method. The original pictures are obtained from 352X288 array of 8 bit samples of luminance component Y and 176X144 array of 8 bit samples of R-Y and B-Y component. R-Y and B-Y are converted to I and Q. The unfiltered luminance Y and two chrominance components I and Q are combined to form the composite NTSC signals on which the separation methods are applied. The separated Y, I and Q components are compared with their original counterparts by computing certain objective criteria in this section. To gain insight into the nature of error, some objective measures for three components are computed as follows. To measure the error distributed overall in the picture, the normalized mean square error and signal/noise ratio in dB are introduced into objective measures.

$$NMSE = \frac{E(|P - P'|^2)}{E(|P|^2)} \quad (21)$$

where P: original image, P': processed image

$$S/N = 10 \log(1/nmse) \quad (22)$$

The block error is introduced to measure the error centralized in the local region.⁽⁷⁾ Let $b_i(M)$, for odd M, denote the M x M block of picture elements around the i-th pel in the picture. Then, the average error in the block is given by

$$b_i(M) = \frac{1}{M^2} \sum_{j \in B_i(M)} |E_j| \quad (23)$$

where E_j is the error in the j-th pel in the block

$B_i(M)$. The n-th absolute moment of these "block errors" is

$$b(n, M) = \frac{1}{N} \sum |b_i(M)|^n \quad (24)$$

where N is the number of picture elements in the picture excluding these in the outside border of width (M-1)/2 and the summation is carried out on these N elements. As M is increased, the value of $b(n, M)$ will decrease more if the errors are dispersed than if they are clustered, since a cluster of error is more objectionable than the same one occurring independently. This value provides a measure for the subjective effects of errors. The comparisons are performed for M=1, 5, which corresponds to having 1, 25 elements respectively in the block. In order to estimate the relative magnitudes of the errors, n=2 and n=5 are used. Because the relatively small error plays a dominant role in the case of n=2, and relatively

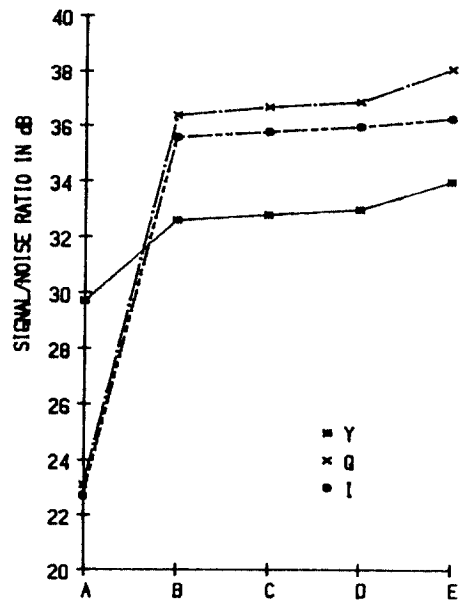

Fig. 11 Signal/noise ratio for the Y, I and Q components. The abscissa axis represent six different separation methods employed, namely, A,B,C,D, and E

large error does the same when $n=5$. The average value of $b(n,M)$ based upon the two pictures are computed for each of the three components Y, I, and Q using $n=2, 5$ and $M=1, 5$. The results

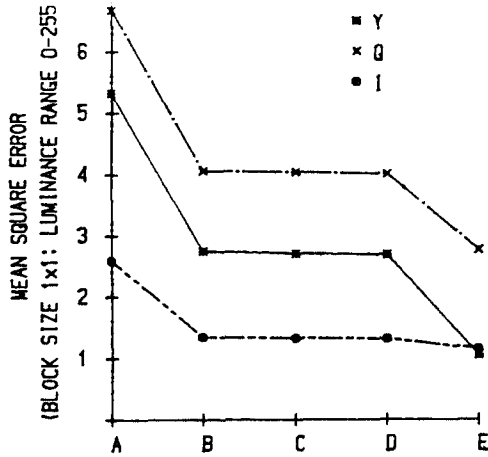

Fig. 12 Mean squares of the average-block error for the Y, I and Q components with block size of 1x1.

of these computation are presented in graphical form in Fig.11-14. It is clear by looking at Fig. 11-14 that the A, B, C, D give poorer result than the E using the proposed algorithm B. The performance of D is somewhat better than the performance of C. But the difference of C and D can be ignored in this image data. As shown in the simulation results, algorithms D and E have the improved performance over the other algorithms

VI. CONCLUSION

In this paper, two adaptive algorithms have been proposed for separating an NTSC signal into its three components Y, I and Q. In the first algorithm A, either a horizontal or vertical filter is chosen to minimize the change in the separated component values subtracted from those neighboring samples which have previously been separated.

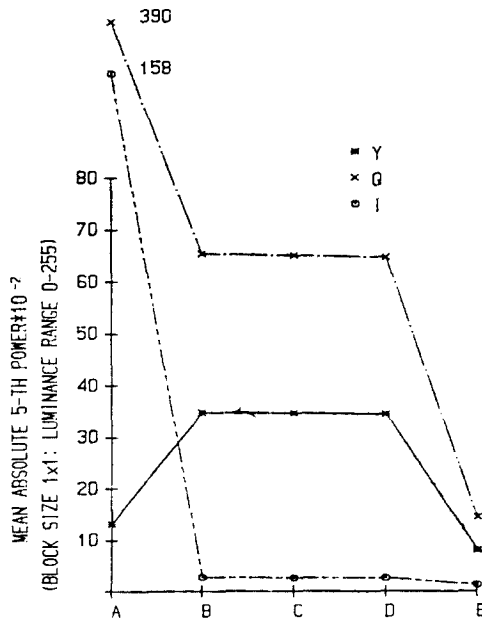

Fig. 13 Mean absolute 5th power of the average-block-error for Y, I and Q components with block size of 1x1.

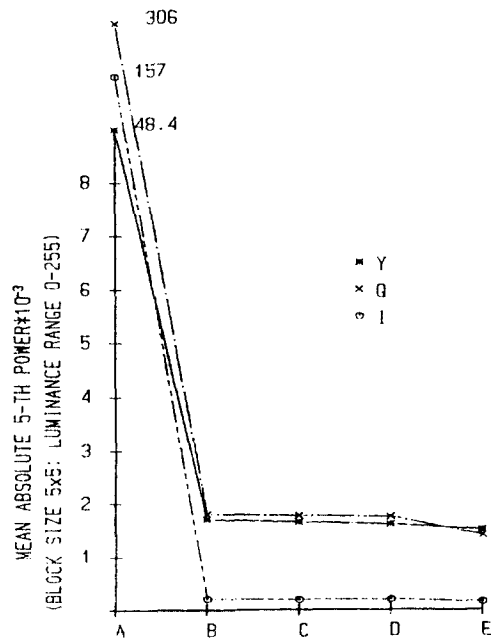

Fig. 14 Same as Fig.13, but with block size of 5x5.

In the second algorithm B, the linear combination detection has been made by the output of horizontal and vertical filters using the detection coefficient α dependent upon the picture change. It has been found that the proposed algorithms have better performances than the conventional methods. The performance of algorithm B is much better than algorithm A, while the algorithm A has the simpler structure than algorithm B requiring multipliers. Thus, the advantageous compromise between algorithm A and B is required for the given circumstances. The interframe processing in three dimensions using frame memory will be the remaining subject for the very efficient component separation.

參 考 文 獻

(1) Y. Ninomiya, Y. Ohtsuka, "A Motion-Compensated Interframe Coding Scheme for NTSC Color Television Signals," IEEE. Trans. on Commun. vol. COM-32, no. 3, pp.328-334. March 1984.

(2) S. Sabri, "Movement Compensated Interframe Prediction For NTSC COLOR TV Sinals," IEEE Trans, on Commun. vol. COM-32, no. 8, pp.954-968. August 1984.

(3) L. van de polder, D. Parker, J. Roos, "Evolution of Television Receivers from Analog to Digital," Proceeding of the IEEE, vol. 73, no. 4, pp.600-612., April 1985.

(4) J. P. Rossi, "Color Decoding a PCM NTSC Television Signal," SMPTE Journal, pp.489-495, January 1977.

(5) A. Kaiser, "Comb Filter Improvement with Spurious Chroma Detection," SMPTE Journal, pp.1-6. January 1977.

(6) L. S. Golding and R. K. Gralow, "Frequency Interleaved Sampling of a Color Television Signal," IEEE Trans. on Commun. pp.972-976 December 1971.

(7) N. Maxemchuk, D. Sharma, "Separation of NTSC Signals by Minimum Mean Square Error Filter and Adaptive Filter," IEEE Trans. on Commun. vol. COM-26, no. 5, pp.583-593, May, 1978.

(8) Y. Nakajima, et. al, "Improvement of Picture Quality for NTSC and PAL System by Digital Signal Processing," IEEE Trans. on CE. vol. CE-31, no. 4, pp. 642-654. November, 1985.

(9) T. Fukinuki, Y. Hirano, H. Yoshigi, "Experiments on proposed Extended-Definition TV with Full NTSC Compatibility," SMPTE Journal, pp. 923-929, October, 1984.

(10) E. Dubois, M. S. Sabri, and J. Y. Ouellet "Three-Dimensional Spectrum and processing of Digital NTSC Color TV Signal," SMPTE Journal, pp.372-378. April, 1982.



李 在 熙 (Jae Hee LEE) 準會員
 1962年 3月 14日生
 1986年 2月 : 光云大學 電子通信 工學科 卒業
 1987~現在 : 光云大學院 電子通信工學科 在學中

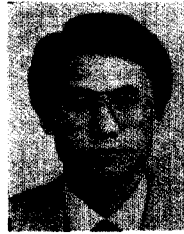

姜 哲 豪 (Cheol Ho KANG) 正會員
 1952年 2月 5日生
 1975年 2月 : 漢陽大學校 電子工學科 卒業
 1979年 2月 : 서울大學校 大學院 電子工學科 卒業
 1977年~1982年 2月 : 國防科學研究所 研究院
 1983年 3月~現在 : 光云大學 電子通信科 (助教授)