

실내벽의 UHF 대역 전파 투과 특성 해석

정회원 김 성 철*

Characterization of Transmission Properties of Two Common Interior Walls at UHF Bands

Seong-Cheol Kim* *Regular Member*

요 약

차세대 근거리 무선 통신망 및 무선 사설교환기 시스템들을 위해서 2.5 GHz 대역의 주파수대역이 광범위하게 사용될 것이 기대된다. 이러한 시스템을 옥내에 설치하여 효율적으로 운용하기 위해서는 전파의 전파 특성의 이해가 중요하다 하겠다. 이 주파수대역의 파장의 길이가 건물의 크기에 비해 상당히 작으므로 광추적 기법을 이용한 전파 전파 예측방식이 많이 개발되고 있다. 그러나 광추적 기법의 정확도는 실내의 벽에서 전파의 반사 및 투과 특성에 의존하는 바가 상당하다. 이에 본 논문에서는 현대 건축물에 흔히 많이 쓰이는 석고보드 벽과 시멘트 블록 벽의 전자파 투과 특성을 이론적 및 실험적으로 분석하였다.

ABSTRACT

The next generation of wireless LAN and PBX systems will make use of the unlicensed band at 2.5 GHz. Deployment of these systems inside buildings requires an understanding of propagation characteristics within buildings. Because the wavelength is small compared to building dimensions, ray methods can be used to predict propagation, but they require knowledge of the transmission and reflection properties of walls. This paper reports on transmission measurements made at walls made of gypsum board on metal studs, and at concrete block walls using directive antennas. The measurements are found to give good agreement with theoretical results that account for the periodic nature of the wall structure.

I. Introduction

The prediction of propagation characteristics inside buildings is important for the design and deployment of wireless communication systems such as personal communication service (PCS), wireless private branch exchange (w-PBX), and

wireless local area network (w-LAN). Statistical analysis of radio communication channels in buildings based on the experimental data of the impulse response and the CW path loss may be adequate to obtain the design parameters of indoor wireless communication systems such as the receiver sensitivity, bit error rate (BER), data transmission rate, link budget based on the distribution function of the received power, and

* 서울대학교 전기공학부 전파 및 무선통신 연구실 (sckim@maxwell.snu.ac.kr)
논문번호 : 99289-0723, 접수일자 : 1999년 7월 23일

so forth. The technical literature has many reports on the measurements and statistical analysis in various UHF bands [1,2,3]. However, statistical analysis will not be sufficient to design for the optimum deployment of a communication systems in the particular building with its unique internal structure.

In order to avoid expensive measurements in individual buildings prior to the installation of a wireless communication systems, or to avoid adjustments afterward installation, many theoretical prediction models using ray tracing have been developed to predict the path loss and delay spread by accounting for the building floor plan [4,5,6]. One of the most important factor to determine the accuracy of these prediction models is believed to be knowledge of the transmission and reflection characteristics of interior and exterior walls, whose contributions to path loss is cumulative as signals launched from the transmitting antenna interact with multiple walls [7].

A common type of interior wall construction in the office building consists of gypsum boards mounted on metal studs, as shown in cross section in Figure 1(a). In order to asses scattering from the metal studs inside the gypsum board wall, measurements were made at 2.4 GHz in a large, unfurnished building. The particular wall used for the study had double layers of gypsum board of total thickness 1.25 inches on either side of the metal studs that are separated by about 2 ft. The results of experiments are compared with the theoretical results accounting for and neglecting the effect of the metal studs. The specular components of the reflected and transmitted fields are found to be dominant for incident angles of 40 from the normal to the wall, although both measurements and calculations show some scattering due to the metal studs.

Another type of interior walls of stores, warehouses, factories, etc., are commonly made of concrete blocks having webs and voids, as shown in Figure 1(b). In order to study the effect of the

webs and voids, which are nearly periodic, on the transmission of UHF radio waves through concrete block walls, measurements were made at 2.6 GHz at a wall composed of concrete blocks that are 17.5 inches long by 8 inches high by 3.5 inches thick with three air voids per a block. These measurements are compared with a rigorous theory for a wall structure with strictly periodic voids having the same dimensions and a periodic spacing equal to the average of the actual wall. Both the theory and measurements show the strong diffraction into non-specular components, at 2.6 GHz.

II. Experimental procedure

The transmitter consisted of a standard gain horn antenna (Tx) driven by a WAVETEK signal generator with frequency range 1-4 GHz. The transmitter was placed on a plastic table for the measurements at the gypsum board wall, and on the mobile industrial cart for the concrete block wall measurements. The receiver system consisted of an identical standard gain horn antenna (Rx), a HP8592A spectrum analyzer and a Laptop computer for data acquisition, and was mounted on a mobile industrial cart. Both receiving and transmitting antennas had a vertical E-field orientation and their center lines stood 32 inches above the floor.

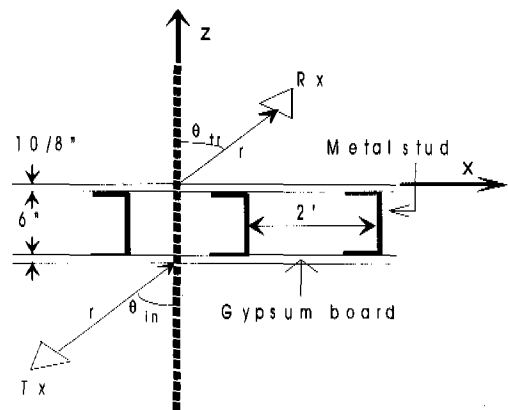

(a) Gypsum board wall

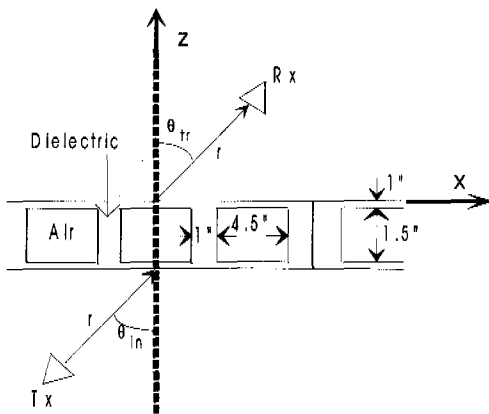

(b) Concrete wall

Fig. 1 Cross section of two interior walls and antennas setup

As shown in the Figure 1, Tx was aimed to give an angle of incidence θ_{in} at a point on the wall located a distance r away from the transmitter. This position was fixed during each set of measurements. To measure the transmitted power, Rx was aimed at the same point on the opposite side of the wall, and was moved along a circle of a radius r . The received power was recorded as a function of the receiver angle θ_{tr} . For the gypsum board wall measurements, r was 11 feet 4 inches, and two different aim points were used. In one set of measurements the aim point was on a metal stud, while in the other set it was midway between two studs. For measurements at the concrete block wall r was 6 ft. In order to avoid interference by reflected or diffracted fields, receiver was located in very large empty rooms whose walls are made of either plaster boards or concrete blocks. For each set of measurements, the system was calibrated by measuring the received power when the two horns faced each other at boresite in a large open space at a separation equal to $2 \times r$ plus the wall thickness. Wall loss is then obtained by subtracting this calibration loss from the measured propagation loss through the wall. Antenna pattern measurements were also made in a large open space by rotating Rx off boresite while Tx was kept stationary. The antenna pattern was then

used in a plane wave spectral approach to predict the variation of the received signal with θ_{tr} in order to compare with the measurements.

III. Theoretical modeling of the plane wave transmission coefficients

The walls considered in this study are approximately periodic structures. The periodicity of the gypsum board wall is due to the metal studs inside, while that of the concrete block wall is due to the air voids and webs, as shown in Figure 1. For a plane wave incident in the x - z plane, the Floquets theorem^[8] require that the transmitted fields be the sum of diffracted orders ($n = \pm 1, \pm 2$), and the specular order ($n = 0$) which makes the same angle with the normal to the wall as the incident plane wave. The resulting electric field can be expressed as

$$E_y(x, z) = \sum_n T_n \exp(-j\beta_n x - jC_n z) \tag{1}$$

where T_n is the transmission coefficient corresponding to n^{th} diffraction order. Here

$$\begin{aligned} \beta_n &= k_0 \sin \theta_i + n \frac{2\pi}{d} \\ C_n &= \sqrt{k_0^2 - \beta_n^2} \end{aligned} \tag{2}$$

where d is the period of the structure and k_0 is the wavenumber in the air. While the sum in (1) extends over all n from $-\infty$ to $+\infty$, when calculating the fields away from the wall surface, it is only necessary to account for the propagating diffraction orders, for which C_n is real.

For a gypsum board wall with period shown in Figure 1 and at a frequency of 2.6 GHz, the diffraction orders for n as high as 10 can propagate along z , depending on the angle of incidence. The transmission coefficients can be found using the moment method as described in references^[9,10,11] to account for the current induced

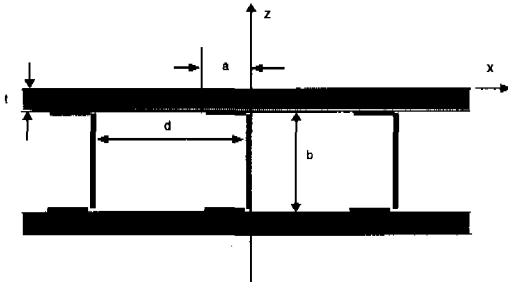

(a) Periodic metal stud of gypsum board wall

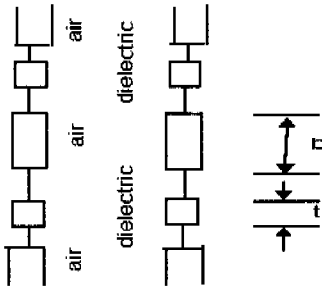

(b) Equivalent transmission line model of gypsum board wall ignoring metal stud

Fig. 2 Schematic diagram of the gypsum board wall

on the periodic metal studs shown in Figure 2(a). Ignoring scattering by the metal studs, the transmission coefficient for the double dielectric layer separated by an air gaps can be calculated using the equivalent transmission line model as shown in Figure 2(b).

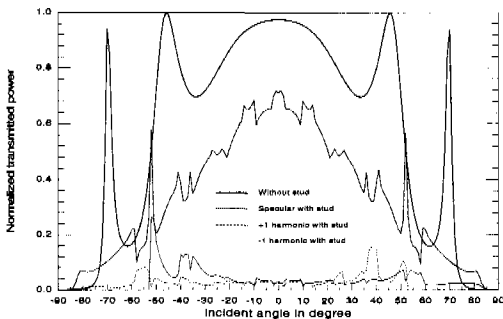

Fig. 3 Power transmission properties through the gypsum board wall at 2.4 GHz

Figure 3 shows the power transmission coefficients of the specular ($n = 0$) and $n = \pm 1$

orders at 2.4 GHz as a function of the angle of incidence calculated by the two methods. The strong variations of the coefficient obtained ignoring the metal studs results from multiple reflection between dielectric layers, and are sensitive to separation and frequency. Accounting for the periodic metal studs, the amplitude of the specular order is somewhat smaller, while the amplitudes of 1 diffraction orders are seen to be considerably smaller than the transmission coefficient obtained ignoring metal studs. The slight asymmetry evident between the +1 and -1 orders' transmission coefficients is a result of the asymmetric shape of the studs. Higher diffraction orders also have small amplitude, so that the specular component carries the most of the power for this structure.

In the case of the concrete block wall, at most only the $n = 0, \pm 1, \pm 2$ diffraction orders can propagate. The ± 1 orders propagate for $-90 < \theta_{in} < 14.24$ and $-14.24 < \theta_{in} < 90$, respectively, while ± 2 orders do so for $-90 < \theta_{in} < -30.94$ and $-30.94 < \theta_{in} < 90$, respectively. The theory for computing transmission through a concrete block wall is given in reference^[12]. In Figure 4 we have plotted the transmission coefficient for the $n = 0, \pm 1$ diffraction orders. It is seen that the ± 1 orders are generally comparable in amplitude to, and sometimes greater than, the $n = 0$ specular order. Thus the concrete block wall gives a greater spreading of the energy than is expected for the gypsum board wall.

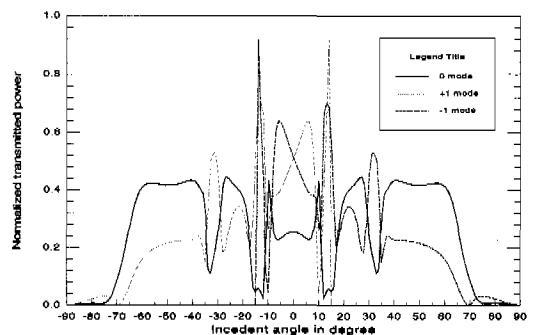

Fig. 4 Power transmission properties through the concrete block wall at 2.6 GHz

IV. Predicting the received signal via Spectral decomposition

The coefficients described in the previous section are for an incident plane wave. However, in the measurements, the walls were illuminated by a beam having the angular spread shown by the horn patterns in Figure 5. In order to compare the measured transmission through the walls with the plane wave theory, it is necessary to account for the angular spreading of the incident field, and for the finite angular resolution of the receiving horn. To this end the field radiated by the horn antenna, as shown in Figure 5, is decomposed into a plane wave spectrum. Neglecting variation of the wall in the vertical (y) direction, the plane wave decomposition can be restricted to the horizontal (x,z) plane.

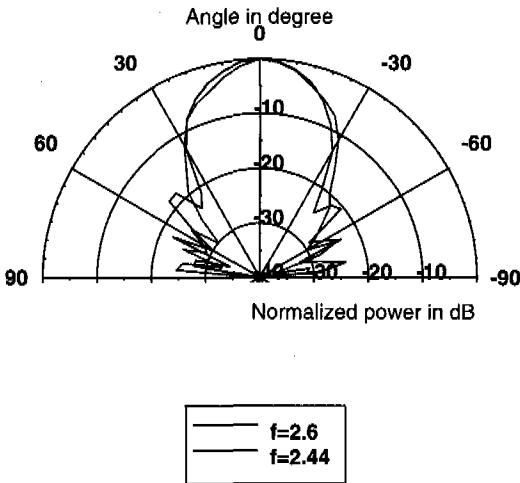

Fig. 5 Radiation pattern of a horn antenna at 2.4 and 2.6 GHz

The plane wave spectrum of $E_y(k_x)$ of the field $E_y(x,0)$ incident on the wall is given by the Fourier transform

$$E_{in}(k_x) = \int_{-\infty}^{+\infty} E_y(x,0) e^{jk_x x} dx \tag{3}$$

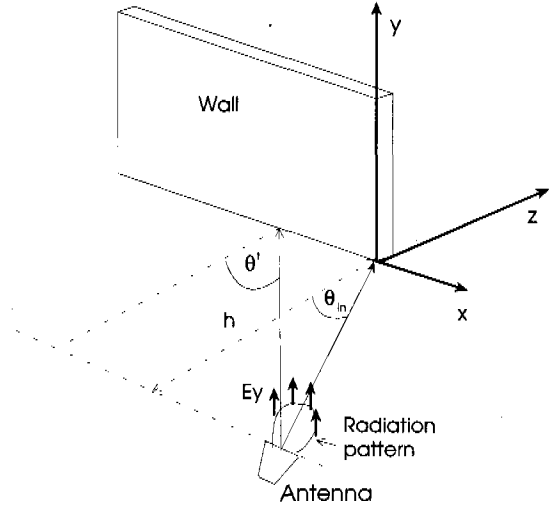

Fig. 6. Relative position of antennas and a wall

Assuming distance h shown in Figure 6 between the transmitting antenna and the wall is large enough so that the wall is in the far field region of the transmitting horn, the radiated field at the plane $z=0$ is given by

$$E_y(x, z=0) = A(\theta' - \theta_{in}) \frac{e^{-jk\sqrt{(x-r\sin\theta_{in})^2+h^2}}}{\sqrt{(x-r\sin\theta_{in})^2+h^2}} \tag{4}$$

where $\theta' = \arctan[(r \sin \theta_{in} - x)/h]$, θ_{in} is the angle of incidence of the beam axis, as shown in Figure 6, and $A(\theta)$ is antenna radiation patterns shown in Figure 5. Because we lack phase information about $A(\theta)$, we assume that it is real. Using this expression in (4), the plane wave spectrum is

$$E_{in}(k_x) = \int_{-\infty}^{+\infty} A(\theta' - \theta_{in}) \cdot \tag{5}$$

$$\frac{e^{-jk\sqrt{(x-r\sin\theta_{in})^2+h^2}}}{\sqrt{(x-r\sin\theta_{in})^2+h^2}} e^{-jk_x x} dx$$

Asymptotic evaluation^[13] of expression (5) leads to the approximated expression

$$E_{in}(k_x) \approx \sqrt{\frac{2\pi}{h}} A(\alpha - \theta_{in}) e^{-j\frac{\pi}{4}} \cdot \frac{e^{-jk\sqrt{k^2 - k_x^2}}}{(k^2 - k_x^2)^{1/4}} e^{jk_x r \sin \theta_m} \quad (6)$$

where $\alpha = \arcsin(k_x/k)$.

Each spectral plane wave incident on the wall excites diffraction orders, so that the transmitted field at (x,z) due to the plane wave is

$$E_{trans}(x,z) = \sum_n T_n(k_x) E_{in}(k_x) e^{-jk_x x} e^{-j\sqrt{k^2 - k_x^2} z} \quad (7)$$

where the sum is taken over the propagating plane wave for $z \gg \lambda$ and $k_{xn} = k_x + 2n/d$. In (7), the coefficient $T_n(k_x)$ describes the transmission into the n diffraction order having transverse wave number k_{xn} .

The antenna pattern in Figure 5 can be viewed as giving the relative amplitude $A(\theta)$ with which the receiving horn detects a plane wave arriving at an angle θ . Thus the received voltage of the horn located at (r, θ_{tr}) is proportional to

$$\sum_n A(\theta'' - \theta_{tr}) T_n(k_x) E_{in}(k_x) \cdot e^{-jk_x r \sin \theta_{tr}} e^{-j\sqrt{k^2 - k_x^2} r \sin \theta_{tr}} \quad (8)$$

where $\theta'' = \tan\left(\frac{k_{xn}}{\sqrt{k^2 - k_x^2}}\right)$.

The total received voltage due to all plane waves radiated by the source is found by substituting (6) for $E_{in}(k_x)$ and integrating over the plane wave spectrum. For $r \gg \lambda$ the integration is taken only over the propagating plane wave so that the voltage is given by

$$\sqrt{\frac{2\pi}{h}} e^{-j\frac{\pi}{4}} \cdot \int_{-k}^k \sum_n A(\theta'' - \theta_{tr}) A(\alpha - \theta_{in}) T_n(k_x) \cdot \frac{e^{-j\sqrt{k^2 - k_x^2}} e^{jk_x r \sin \theta_m} e^{-jk_x r \sin \theta_{tr}}}{(k^2 - k_x^2)^{1/4}} \cdot e^{-j\sqrt{k^2 - k_x^2} r \cos \theta_{tr}} dk_x \quad (9)$$

As in the case of the measurements, the computations are normalized to the power received when the two horns face each other at boresite for the same separation used in the measurements. For the computation of reference power, $\theta_{tr} = 0$, $T_n = \delta_{n,0}$ and $k_{xn} = k_x$. Numerical integration is used to evaluate (9).

V. Results and discussion

Figure 7 compares the measured and computed results for transmission through the gypsum board wall for normal incidence. The dots and triangles refer to measured transmission loss taking the aiming point between studs and on a stud, respectively. There appears to be no systematic difference for the two aiming points. Measurements are a little lower than the results predicted by ignoring the studs, while they are well matched to the predictions made accounting for the ± 1 diffraction orders, in addition to the specular component, in the angle range between -60° and 60° . Outside this angle range, the measured transmission is stronger than the predictions, which is believed to be due to neglecting the higher diffraction orders' contribution. The angular asymmetry of the theoretical predictions is due to the asymmetry of the studs themselves, and this asymmetry is evident in the measurements.

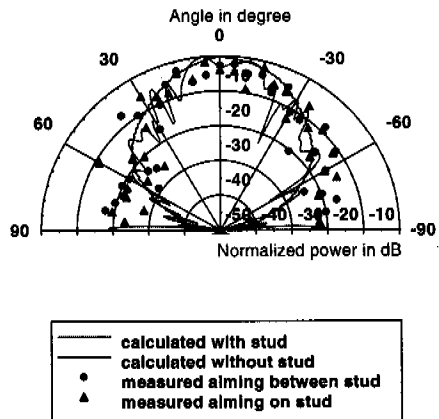

Fig 7. Transmitted power through the gypsum board wall with normal incidence

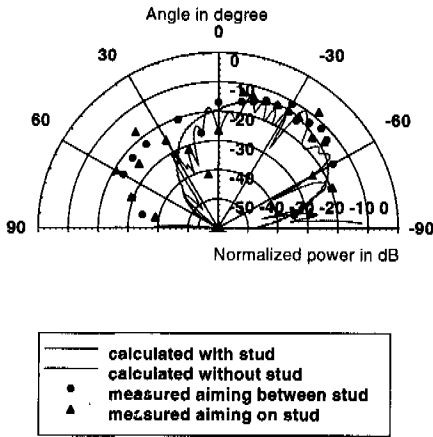

Fig. 8 Transmitted power through the gypsum board wall with an incident angle of -30 degree with respect to normal

The measured and computed transmission loss for the case of oblique incidence at -30° from normal direction are shown in Figure 8. As in the case of normal incidence, the specular components are seen to be primarily responsible for carrying the incident energy away from the wall, and in the vicinity of the specular direction good agreement is found for the theory ignoring scattering by the metal studs. In the range from 0° to 30° and from -60° to -90° the variation of the transmitted power is in closer agreement with the theory that includes scattering by the studs. However, the scattering of ± 1 diffraction orders is not sufficient to explain the strong transmission found in the range from 30° to 60° .

The transmission loss obtained for normal incidence on a concrete block wall are shown in Figure 9. Measurements, represented by filled circles, are seen to be in good agreement with the theory. Comparing the theoretical results of Figure 7 and Figure 9, it is seen that the strong excitation of the $n = \pm 1$ diffraction orders in the concrete blocks causes significant scattering of the incident energy into non-specular directions, while for the gypsum board those diffraction order are relatively small, as shown in Figure 3. Results for incidence at -30° on a concrete block wall are

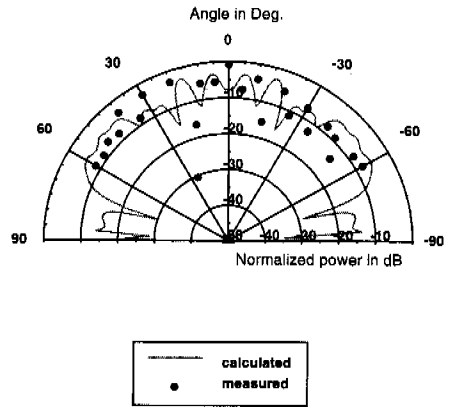

Fig. 9 Transmitted power through the concrete block wall with normal incidence

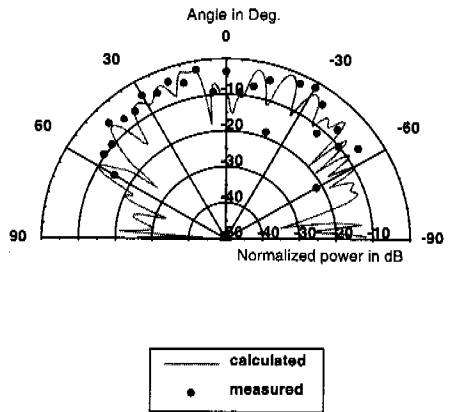

Fig. 10 Transmitted power through the concrete block wall with an incident angle of -30 degree with respect to normal

shown in Figure 10. Again good overall agreement is obtained between theory and measurements. It is seen from Figure 10 that the energy is spread over an angular range that is almost as wide as for the case of normal incidence. This can be explained by the fact that for incidence near -30° the transmission coefficients of $+1$ diffraction order are larger than that of specular order, as seen from Figure 4. These experiment results justify modeling the concrete block wall as a periodic structure. Since large retail stores make extensive use of concrete

block construction, scattering of energy at such walls may effect coverage and delay spread of systems operating in the 2.5 GHz band. At 900 MHz since the $n = 1$ diffraction orders do not propagate away from the wall, so that reflection and transmission take place only in the specular direction.

IV. Conclusion

The results of experiment and theoretical modeling of transmission characteristics of two typical interior walls are given in this paper. For the gypsum board wall, the simplified model that ignores the effect of metal studs is adequate for describing transmission because the transmitted power of the specular mode is much stronger than that of the diffraction orders. However when the scattering effect of the metal studs included, the better agreement with the measured transmission loss is found. For a smaller spacing between metal studs, scattering effects may become more important. The rigorous model of the concrete block wall, which predicts the existence of space harmonics in the frequency band above 1 GHz, gives an accurate description of the transmission through the wall.

References

- [1] T. S. Rappaport, "Indoor Radio Communications for Factories of the Future," *IEEE Communications Magazine*, pp. 15-24, May 1989.
- [2] A. Saleh and R. Valenzuela, "A Statistical Model for Indoor Multipath Propagation," *IEEE Journal of Select. Areas in Communication*, Vol. SAC-5, No 2, pp. 128-137, Feb. 1987
- [3] S. C. Kim, H. L. Bertoni, and M. Stern, "Pulse Propagation Characteristics at 2.4 GHz Inside Buildings," *IEEE Trans. on Vehicular Technology*, Vol. 45, No. 3, pp. 579-592, 1996.
- [4] W. Honcharenko, H. L. Bertoni, J. L. Dailing, J. Qian, and H.D. Yee, "Mechanisms Governing UHF Propagation on Single Floors in Modern Office Buildings," *IEEE Trans. on Vehicular Technology*, Vol. 41, No. 4, pp. 496-504, Nov. 1992.
- [5] S. Y. Seidel and T. S. Rappaport, "914 MHz Pathloss Prediction Model for Indoor Wireless Communication in Multifloor Buildings," *IEEE Trans. on Antennas and Propagation*, Vol. 40, No. 2, pp. 207-217, Feb. 1992
- [6] J. W. McKnown and R. L. Hamilton, "Ray Tracing as a Design Tool for Radio Network," *IEEE Network Magazine*, Vol. 5, No. 6, pp. 27-30, Nov. 1991.
- [7] S. Fortune, D. M. Gay, B. W. Kernigham, O. Landron, R. A. Valenzuela, and M. H. Wright, "WISE Design of Indoor Wireless Systems," *IEEE Computational Science & Engineering*, Spring 1995, pp. 58-68.
- [8] D. A. Watkins, *Topics in Electromagnetic Theory*. New York: John Wiley & Sons, Inc., 1958, pp. 1-38.
- [9] J. P. Montgomery, "Scattering by an Infinite Periodic Array of Thin Conductors on a Dielectric Sheet," *IEEE Trans. on Antennas and Propagation*, Vol. AP-23, No. 1, pp. 70-75, 1975.
- [10] B. J. Rubin and H. L. Bertoni, "Scattering from a Periodic Array of Conducting Bars of Finite Surface Resistance," *Radio Science*, Vol. 20, No. 4, pp. 827-832, July-August, 1985.
- [11] J. Lenormand, B. Bougerolles, C. Terret, E. Marouby, and J. R. Levrel, "Analytical Expressions of the Reflection and Transmission Coefficients through a Perfectly Conducting Inductive Screen Sandwiched between lossy Dielectric Slabs," *International Conference on Electromagnetics in Aerospace Applications*, Torino, Italy, pp. 75-78, 1991.
- [12] W. Honcharenko and H. L. Bertoni, "Transmission and Reflection Characteristics at Concrete Block Walls in UHF Band Proposed for Future PCS," *IEEE Trans. on Antennas and Propagation*, Vol. 42, pp.

232-239, Feb. 1994.

- [13] L. B. Felsen and N. Marcuvitz, *Radiation and Scattering of Waves*. IEEE Press, 1994, pp. 370-421.

김 성 철(Seong-Cheol Kim)

정회원

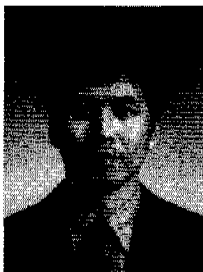

1984년 : 서울대학교 전기공학
과, 학사

1987년 : 서울대학교 전기공학
과, 석사

1995년 : Polytechnic University,
박사

1999년 3월 현재 : 서울대학교
전기공학부, 조교수

<주관심 분야> 전파 전파, 통신 채널 모델링