

균일 및 주파수 선택적 페이딩에서 대역폭 효율의 적응 QAM 성능분석

정회원 정연호*

Performance Evaluation of Bandwidth Efficient Adaptive QAM Schemes in Flat and Frequency Selective Fading Channels

Yeon Ho Chung* *Regular Member*

ABSTRACT

This paper presents the performance evaluation of an adaptive QAM scheme under flat and frequency selective fading channels for indoor wireless communication systems. The QAM modulation is combined with differential encoding and the demodulation process is carried out noncoherently. The adaptation is performed by varying the modulation level of QAM, depending upon received signal strength. The adaptation mechanism allows a 2- or 3-bit increase or decrease at a time, if the channel condition is considered to be significantly good or bad. Simulation results show that the average number of bits per symbol (ABPS) for each symbol block transmitted over a flat fading channel is higher than 5.0 and the BER performance is better than 10^{-4} for a SNR value higher than 30 dB. For frequency selective fading channels, an oversampling technique in the receiver was employed. The BER performance obtained for frequency selective fading channels is better than 10^{-4} with a SNR value of 40 dB and ABPS is found to be approximately 5.5. Therefore, this scheme is very useful in that it provides both very high bandwidth efficiency and acceptable performance with moderate SNR values over flat and frequency selective fading channels. In addition, this scheme provides reduced receiver complexity by way of noncoherent detection.

I. Introduction

The provision of multimedia communication services in wireless personal communication systems is one of the most important issues in the next generation mobile radio system. In order to satisfy this requirement, a spectrally efficient and flexible data transmission scheme according to instantaneous propagation conditions is needed. Multilevel quadrature amplitude modulation (QAM) is very effective in achieving high bit rate transmission using a limited bandwidth^[1]. However, in fading channels, the severe amplitude

and phase changes occur and these often lead to a high bit error rate (BER) in QAM symbol transmissions. A recent study suggests that, by means of controlling the modulation level adaptively, the QAM scheme can be applied to Rayleigh fading channels with acceptable performance^[1,2]. In other words, adaptive QAM (AQAM) scheme is a viable modulation scheme in fading channels where high data throughput is one of the important design considerations. As the mobile radio channel often exhibits time delays, the applicability of AQAM to frequency selective fading channel environments needs to be

* Dongeui University Dept. of Information and Communications,
논문번호: 00270-0714, 접수일자: 2000년 7월 14일

* This work was supported by Korea Research Foundation Grant (KRF-99-003).

addressed. Previous contributions in frequency selective fading channel environments attempted to mitigate the effect of channel delays by employing multicarrier transmission or an equalizer^[3,4]. In this paper, an oversampling technique in the receiver was employed for mitigating intersymbol interference (ISI) present in frequency selective fading channels. Although channel delays affect the performance of AQAM, the proposed method gives an improvement in performance while maintaining high data throughput. In addition, by employing noncoherent detection, the receiver complexity is significantly reduced. In the following, the adaptive QAM schemes and adaptation mechanism are presented. In Section 3, the adaptive QAM simulator is described and simulation results are provided in Section 4. Conclusions are drawn in Section 5.

II. Noncoherent Adaptive QAM Schemes

1. Adaptive QAM scheme

In QAM modulation schemes, two possible arrangements of QAM constellation points are generally considered: square and circular shaped QAM constellation. Previous studies show that over Rayleigh fading channels, a circular shaped QAM is preferred^[2]. It is known that differential encoding process helps mitigate fading effects more efficiently, although this may reduce the performance slightly due to its encoding nature. In this paper, a circular QAM combined with differential encoding is thus considered. The adaptation is performed on the modulation level, according to propagation conditions, so that the modulation level is varied from 2-QAM (BPSK) up to 64-QAM. The present study considers the number of amplitude rings limited to 2. As an example, the arrangement of 32-QAM is shown in Figure 1.

This restriction would not exhibit an adverse effect on the performance, since multilevel modulation schemes are generally employed in propagation environments where low vehicle

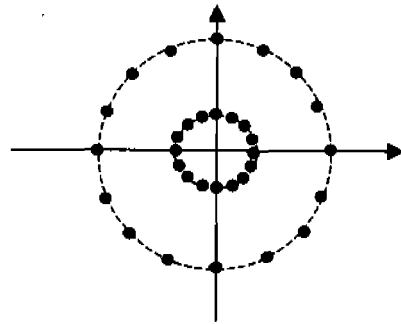

Fig. 1 Constellation diagram of 32-QAM

speeds and low delays are anticipated. In fact, this would ease both the differential decoding process and the necessity of exact amplitude information. In general, a QAM-modulated signal can be expressed as:

$$s(t) = I(t) \cos 2\pi f_c t - Q(t) \sin 2\pi f_c t \quad (1)$$

where

$$\begin{aligned} I(t) &= A_m g_T(t) \cos \theta_n \\ Q(t) &= A_m g_T(t) \sin \theta_n \quad m=1,2,\dots,M_1, n=1,2,\dots,M_2 \end{aligned}$$

Note that A_m and $g_T(t)$ denote the amplitude of a QAM symbol and pulse shaping filter response, respectively and f_c is carrier frequency. As mentioned earlier, M_1 is limited to 2 and M_2 is the number of QAM phases in each amplitude ring.

When the modulation level of QAM is decided in the receiver (to be discussed later), that information is fed back to the transmitter and then the mapping of the information bits to a QAM constellation point takes place. At this point, the differential encoding is performed. For example, consider a 16-QAM differential modulation. The first bit corresponds to the amplitude ring and is differentially encoded, i.e. if the first bit is '0', then no change of amplitude ring occurs, while if the first bit is '1', then the amplitude ring is changed to the one not used in the previous symbol. The remaining three bits are also differentially encoded and then mapped to a constellation point in the identified ring. The

QAM-modulated signal is transmitted over the mobile radio channel where flat or frequency selective fading takes place. The discussion of adaptation mechanism is now presented below.

2. Adaptation Mechanism

One of the most important issues in adaptive modulation schemes is the accuracy and reliability of an adaptation parameter, based on which the increase or decrease of the modulation level is initiated. In the present study, the strategy for the selection of QAM level is based on the assumption that the channel does not vary significantly over two symbol blocks. Thus, the QAM modulator in the transmitter directly utilizes the number of bits per symbol fed from the receiver. This is based on the assumption that an error-free transmission of the number of bits per symbol is made. The adaptation mechanism operates in the receiver. The receiver first performs differential adaptive QAM demodulation and the recovered data are compared with its original data, thereby obtaining BER. After this demodulation, the receiver initiates the adaptation process in which the number of bits per symbol to be used for the next symbol block is determined. The mechanism begins by measuring the received signal strength based on the signal for the present symbol block. This signal strength indicates what number of bits per symbol is appropriate to be used in the transmitter by way of making a comparison with an initial threshold. Depending upon how much the signal level is increased or decreased, the scheme carefully decides to increase or decrease the number of bits per symbol. The proposed scheme allows a 2- or 3-bit increase or decrease at a time, if the measured signal level is significantly high or low. This operation is carried out systematically by arranging a number of thresholds with an appropriate step size. That is, the received signal level is first compared with the thresholds and then a proper threshold can be found. Based on the signal level of the previous symbol block, the number of thresholds moved up or down, with

respect to the previous threshold, is obtained. This information facilitates the number of bits per symbol to be used for the forthcoming symbol block. It is important to note that this adaptation mechanism is based entirely on the present signal level without employing any reference signal in the transmitter. Moreover, the process does not compare with a predefined BER, in order to select the QAM level. The information of the number of bits per symbol thus obtained is fed back to transmitter for use in the forthcoming symbol block.

3. Throughput of AQAM in Rayleigh Fading Channels

The throughput analysis of AQAM in fading channels is made by way of general QAM performance analysis. The performance of QAM for an AWGN channel can be obtained by viewing a symmetrical QAM as two separate PAM signals impressed on phase-quadrature carriers^[5]. The symbol error probability of QAM is upper bounded as follows^[5]

$$P_s \leq 2\text{erfc}\left(\sqrt{\frac{3\gamma}{2(M-1)}}\right) \quad (2)$$

where M is the number of symbols and γ is the signal and noise plus interference ratio (SINR).

For $0 \leq \gamma \leq 30$, Eq.(2) can be approximated as^[6]

$$P_s \approx 0.2 \exp^{-1.5\gamma/(M-1)} \quad (3)$$

From Eq.(3), we have

$$M(\gamma) = 1 + c_1 \gamma \quad (4)$$

where c_1 is a constant for a specific probability of error.

Therefore, the throughput of QAM for a AWGN channel can be written as

$$T(\gamma) = \log_2 M(\gamma) = \log_2(1 + c_1 \gamma) \quad (5)$$

The throughput of AQAM for Rayleigh fading channels can be derived from Eq.(5). Here, a single user environment is assumed in the subsequent analysis. The probability density function of the instantaneous SINR is given by

$$p(\gamma) = \frac{1}{\Gamma} \exp^{-\gamma/\Gamma}, \quad \gamma \geq 0 \tag{6}$$

where Γ is the average SINR. Then, the average probability of error is written as

$$\begin{aligned} \langle P_e \rangle &= \int_0^{\infty} 0.2 \exp^{-1.5\gamma/(M-1)} p(\gamma) d\gamma \\ &= \frac{0.2}{\left(1 + \frac{1.5\Gamma}{M-1}\right)} \end{aligned} \tag{7}$$

Therefore, we have

$$M(\Gamma) = 1 + c_2 \Gamma \tag{8}$$

where c_2 is a constant for a specific average probability of error. Therefore, from Eq.(8), it can be said that the data throughput for Rayleigh fading channels is dependent upon average SINR for a given average probability of error.

III. Adaptive QAM Simulator

In order to evaluate the performance of the proposed scheme efficiently, an adaptive QAM simulator has been developed using ACOLADE^[7] that is a communication-oriented software platform. It is completely versatile, which makes it possible to investigate various aspects of a QAM system. Figure 2 shows the top level block diagram of the AQAM simulator.

This simulator allows any simulation parameters (e.g. mobile speeds, block size, flat or frequency selective fading, etc.) to be easily altered in order to analyze the BER performance under various channel conditions in the system. All the blocks in the simulator have been created in a hierarchical manner and a brief functional description of each block is given below. The

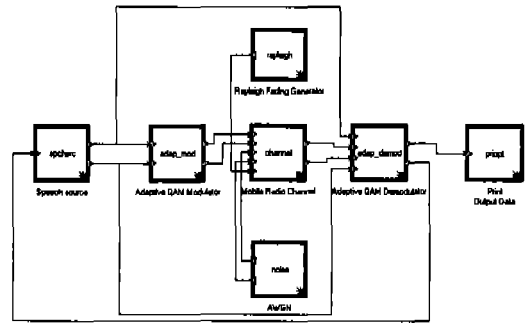

Fig. 2 shows the top-level block diagram of the adaptive QAM simulator.

first block of the simulator generates speech data to be simulated and it passes the data to the modulator where the differentially encoded QAM is performed. After the QAM modulation, the data are passed to the channel block where a flat or frequency selective fading occurs, together with an additive white Gaussian noise added. The first block in the receiver is a QAM differential demodulation. The demodulated data are compared with the original data and a bit error rate is obtained. Details of the functionality and implementation of the blocks in the simulator can be found in Reference 8.

IV. Simulation and Results

By making use of the adaptive QAM simulator, simulation was carried out with a number of different mobile speeds, symbol rates, and so on. In the present study, a single user environment is considered. The values of simulation parameters are as follows: the symbol rate is 32kbaud, the carrier frequency is 1 GHz, and the symbol block size is 100. A total of 700 blocks (70,000 symbols) were submitted to the simulator for all simulation scenarios, to observe the performance variation with respect to SNR values.

1. BER Performance and ABPS with Different Mobile Speeds

Figure 3 shows the BER performance with different mobile speeds. It should be noted that

although high mobile speeds are not generally considered with multilevel QAM modulations, an attempt was made for the purpose of performance comparison. It can be seen that the increase of mobile speed degrades the BER performance. This is due to the fact that the adaptation parameter is no longer accurate with a high fading rate and thus more errors occur. Nevertheless, it was found that for the mobile speeds less than 35 km/h, the BER performance is better than 10^{-3} with a SNR value of 30dB or higher.

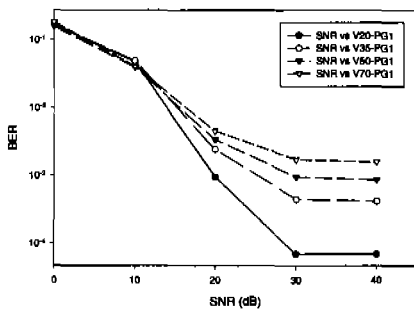

Fig. 3 BER performance with different mobile speeds

Table 1 shows the average number of bits transmitted for each block. In all simulation scenarios, the average number of bits per symbol is found to be higher than 5.0, which imply a bit rate of approximately 160 kbps achievable.

Table 1. Average data throughput for different mobile speeds (in Km/h)

SNR (dB)	Mobile speeds			
	V20	V35	V50	V70
0	5.59	5.55	5.29	5.67
10	5.76	5.81	5.42	5.13
20	5.15	5.76	5.66	5.52
30	5.15	5.76	5.66	5.69
40	5.15	5.76	5.67	5.69

2. BER Performance and ABPS with Different Symbol Rates

The performance evaluation has also been made by varying the symbol rate, while the mobile speed is fixed to 35 km/h. Symbol rates of 70k, 100k and 200kbaud were considered and the

performance comparison was made. Figure 4 shows the BER performance variation with different symbol rates. It can be seen that the performance improves as the symbol rate increases. The reason for this is that, with the fading rate fixed, the smaller symbol duration would be less affected by fading.

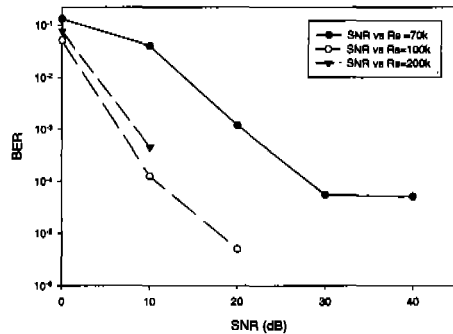

Fig. 4 BER performance with different symbol rates

Table 2 shows the average data throughput for different symbol rates. The average data throughput for the symbol rate of 200kbaud is still as high as 4.0. This is equivalent to 800 kbps. It is observed that ABPS becomes higher as symbol rate decreases.

Table 2. Average data throughput for different symbol rates (V=35Km/h)

SNR (dB)	Symbol Rates			
	32k	70k	100K	200k
0	5.55	4.93	3.34	4.0
10	5.81	5.57	3.34	4.0
20	5.76	5.57	3.34	4.0
30	5.76	5.57	4.05	4.0
40	5.76	5.57	4.05	4.0

3. BER Performance and ABPS in Frequency Selective Fading Channels

For the performance evaluation of the proposed scheme over frequency selective fading channels, a wideband propagation environment was created. Figure 5 shows a channel model for outdoor urban/suburban low-rise low antenna (channel B)

environments specified in Reference 9.

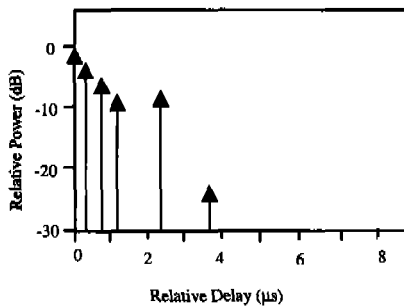

Fig. 5 wideband channel model(urban/suburban channel B)

The delay spread is defined as^[10]

$$S = \sqrt{\frac{\int_0^{\infty} (\tau - D)^2 P_h(\tau) d\tau}{\int_0^{\infty} P_h(\tau) d\tau}} \quad (9)$$

where D is the average delay, τ is excess delay and $P_h(\tau)$ is the average power delay profile. Using Eq.(9), the delay spread for this model is found to be 0.75 μ sec.

A wideband channel was implemented by using the approach (a tapped delay line model) described in References 8 and 10. In the wideband channel model, it is ensured that each path undergoes an independent Rayleigh fading. An oversampling ratio of 2 was utilized, prior to AQAM demodulation. For the given channel environment, the BER performance is shown in Figure 6, with the mobile speed fixed to 20km/h. With a SNR value of 40dB, the BER performance is better than 10^{-4} . As shown in Table 3, ABPS for this environment is also higher than 5.0 for all SNR values.

Table 3. Average data throughput for frequency selective fading channels (V = 20Km/h)

SNR (dB)	ABPS
0	5.61
10	5.60
20	5.48
30	5.48
40	5.68
50	5.68

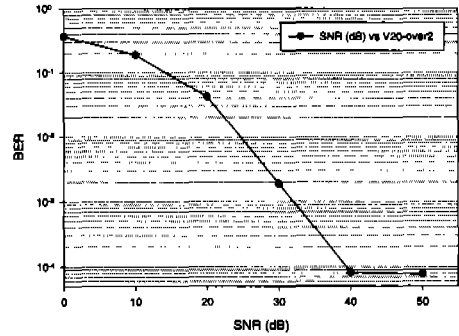

Fig. 6 BER performance of AQAM for frequency selective fading channels

V. Conclusions

In this paper, an adaptive QAM scheme with noncoherent detection was considered. This scheme was applied to flat (narrowband) and frequency selective fading (wideband) channels, in order to observe the BER performance. Under the assumption of low mobile speeds and low delays, the scheme provides very high data throughput, approximately higher than 5.0 bits per symbol block on average, for both narrowband and wideband channel environments. This throughput is achieved without sacrificing the BER performance, because the scheme shows acceptable BERs with moderate SNR values. Further investigations were undertaken by increasing symbol rate and varying mobile speed, in order to observe performance variation. Under these scenarios, relatively high data throughput was also obtained. Hence, this scheme is useful to provide very high bandwidth efficiency for high-speed indoor wireless communication systems where low delays and low mobile speeds are expected. It will be interesting that this scheme is compared with other delay compensation techniques in AQAM over frequency selective fading channels. This investigation is left for future work.

References

[1] Webb, W.T., "Variable rate QAM for mobile radio", *IEEE Trans. Comm.* Vol.43, No.7,

pp.2223-2230, July 1995

[2] Webb, W.T., Hanzo, L. and Steele, R., "Bandwidth efficient QAM schemes for Rayleigh fading channels", IEE Proc.-I, Vol.138, No.3, pp.169-175, June 1991

[3] Hamaguchi, K. and Moriyama, E., "Performance of multicarrier/QAM-level-controlled adaptive modulation for land mobile communication systems", IEICE Trans. Comm., Vol. E81-B, No.4, pp.770-776, April 1998

[4] Wong, C.H. and Hanzo, L., "Upper-bound performance of a wideband adaptive modem", IEEE Trans. Comm., Vol.48, No.3, pp.367-369, March 2000

[5] Proakis, J.G., Digital Communications, 2nd Ed. McGraw-Hill, 1989

[6] Qiu, X. and Chawla, K., "On the performance of adaptive modulation in cellular systems", IEEE Trans. Comm., Vol.47, No.6, pp.884-895, June 1999

[7] ACOLADE, User manual, 1996, <http://www.icucom.com>

[8] Y.H.Chung, "The performance of subjective speech quality and BER in a GSM-based system", IEICE Trans. Comm., Vol.E81-B, No.10, pp.1944-1945, October 1998.

[9] JTC(AIR), Radio System Characterization for the Proposed IS-95 Based CDMA PCS Standard

[10] J.D.Parsons, The Mobile Radio Propagation Channel, Pentech Press, 1992

[11] Cavers, J.K., "An analysis of pilot symbol assisted modulation for Rayleigh fading channels", IEEE Trans. Veh Tech., Vol.40, No.4, pp.686-693, Nov. 1991

정연호(Yeon Ho Chung)

1984년: 경북대학교 전자공학과 (공학사)
 1992년: Imperial College, The University of London, U.K. (공학석사)
 1996년: Liverpool University, U.K. 전기전자공학과 (공학박사)
 1985년 3월~1990년 8월: 외무부/주영국대사관 근무
 1994년 11월~1996년 7월: Liverpool University 연구강의 조교
 1994년 11월~1995년 1월: (주)FCL 기술 자문역 (이동통신 시스템 설계 및 개발)
 1996년 8월~1999년 2월: 경북대학교 전자전기공학부 초빙교수
 1999년 3월~현재: 동의대학교 정보통신공학과 전임강사
 <주관심 분야> 이동통신 채널 측정/특성화, 이동통신 시스템 설계, 적응성 변조 기술, 이동통신 시스템 음질