

# A Study on the PAPR Reduction by Hybrid Algorithm Based on the PTS and GS Technique

Zi-Bin Zhao\*, Young-Hwan Kim\* *Associate Members*, Jae-Moung Kim\* *Lifelong Member*

## ABSTRACT

Multicarrier systems has major shortcomings due to the large numbers of subcarrier. One of the shortcomings is the high peak-to-average power ratio(PAPR), which causes nonlinearity distortion in the transmitter, and degrades the performance of the system significantly. Partial transmit sequence(PTS) is one of the best approaches that can significantly improve the statistics of the PAPR of an orthogonal frequency division multiplexing(OFDM) signal. Guided scrambling(GS) is an extension of self-synchronizing scrambling. It is also capable of guiding the scrambling process to produce a balanced encoded bit stream. In this paper, we propose a sub-optimal algorithm to optimize the phase factor in PTS. In addition, we integrate GS coding with this method. The proposed Hybrid algorithm can get much more PAPR reduction at the expense of incur a few error extension and do not require transmission of side information.

**Key Words** : peak-to-average ratio, PTS, guided scrambling, OFDM, side information

## I. Introduction

In order to satisfy the high demands of future wireless communication systems, many Multicarrier systems have been promised. Among them, orthogonal frequency division multiplexing(OFDM) is one of the most interested. As it has inherent resistance to inter-symbol interference(ISI) and requires simple equalizers to recover the signals from a fading channel. However, one of the serious drawbacks of the OFDM signals is the high PAPR which causes the nonlinear distortion and the power penalty at the transmitter.

Conventional solutions to reduce PAPR are to use a linear amplifier or to back-off the operating point of a nonlinear amplifier<sup>[1]</sup>. But, both solutions result in a significant loss of power efficiency. Several alternative solutions have been proposed. The simplest is to deliberately clip the OFDM signal before amplification<sup>[2]</sup>. However, clipping may cause in-band and out-of-band noise.

Another solution uses block coding where the desired data sequence is embedded in a larger sequence and only a subset of all the possible sequences are used, specifically, those with low peak powers<sup>[3]</sup>. While the block coding can reduce PAPR, they also reduce transmission rate, significantly so for a large number of subcarriers<sup>[4]</sup>. In addition, large look-up tables are required to implement this coding scheme, limiting its usefulness to applications with a small number of subchannels.

Recently, two promising techniques to reduce the PAPR of an OFDM signal have been proposed: the selective mapping(SLM) and partial transmit sequence(PTS) approaches<sup>[5, 6]</sup>. In SLM, at the transmitter, one favorable signal is selected from a set of different signals which all represent the same information. In PTS, the transmitted signal is made to have low PAP by optimally combining signal subblocks. Compared to these two methods, simulation studies in<sup>[6]</sup> show that the performance

※ 본 연구는 정보통신부 및 정보통신연구진흥원의 대학 IT연구센터 지원사업의 연구결과로 수행되었음(IITA-2005-C1090-0502-0030).

\* 인하대학교 무선전송연구실 (zhaochen1124@hotmail.com, yhsnail@korea.com, jaekim@inha.ac.kr)

논문번호 : KICS2005-10-433, 접수일자 : 2005년 10월 25일

of PTS is better than SLM in PAPR reduction, if the same number of IFFT's are considered. PTS is an attractive scheme because it will not introduce any distortion and can apply for any signal constellation of any subcarrier size. However, in order to recover the data, the receiver must know which inversion sequence was used to modify the transmitted data. So, the PTS method needs to send the side information, which will lead to some loss in the efficiency.

Guided scrambling(GS) is a multimode coding techniques based on the same premise as PTS: generate multiple representations of each source sequence and select the representation that best satisfies the given constraint<sup>[7]</sup>. Moreover, it does not need transmission of side information. When a scrambled binary sequence with a high proportion of 1s or 0s is applied to an N-point IFFT OFDM modulation, it will generate subcarrier phases that tend to align at some point in time, thereby giving a signal with relatively high PAPR.

Conversely, a scrambled binary sequence of length 2N with a hamming weight close to N will often generate low PAPR<sup>[8]</sup>. GS is capable of guiding the scrambling process to produce a balanced encoded bit stream. Since the correlated pattern among subcarriers influences the PAPR, which is highly dependent on the patterns of the orthogonal subcarriers used. This implies that the PAPR of the OFDM signal will be reduced if we can introduce a disturbance into the correlation among the subcarriers.

We can achieve a further PAPR reduction by using the fixed scrambling patterns and holding the scramble pattern. So, we expected that combined the GS with Sub-Optimal PTS can get significant reduction of PAPR.

## II. Partial Transmit Sequences

### 2.1 Characteristics of OFDM Signal

In OFDM, a block of N transmitted symbols is demonstrated as  $\{X_n, n = 0, 1 \dots N-1\}$ . And each symbol is modulated to one of a set of subcarriers,  $\{f_n, n = 0, 1 \dots N-1\}$ . Every subcarriers are orthogonal, that is,  $f_n = n\Delta f$ , where  $\Delta f =$

$1/NT$  and T is the original symbol period. The resulting signal is as

$$X(t) = \sum_{n=0}^{N-1} X_n e^{j2\pi f_n t}, \quad 0 \leq t \leq NT \quad (1)$$

The PAPR of the transmitted signal in (1) can be defined as

$$PAPR = \frac{\max |x(t)|^2}{E[|x(t)|^2]} \quad (2)$$

### 2.2 Ordinary PTS Technique

Fig. 1 shows that in the ordinary PTS technique<sup>[2]</sup>, the input data block X is partitioned into M disjoint sub-blocks  $X_m = [X_{m1}, X_{m2}, \dots, X_{mN}]^T, m = 1, 2, \dots, M$ . These are called as the partial transmit sequences. Phase factors,  $b_m = e^{j\phi_m}, m = 1, 2 \dots M$ , are introduced to combine with the partial transmit sequences to reduce the PAPR. The phase factors can also write as a vector  $b = [b_1, b_2 \dots b_M]^T$ . So, after combining, the time-domain signal sample is given by

$$X'(b) = \sum_{m=1}^M b_m x_m \quad (3)$$

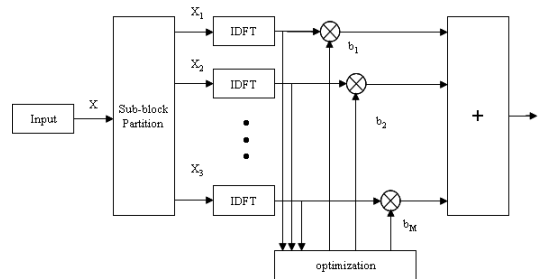

Fig. 1. Block diagram of partial transmit sequence

Where  $x'(b) = [x'_1(b), x'_2(b) \dots x'_{NL}(b)]^T$ . Minimization of PAPR is equivalent to find the weighting factor to minimize the  $\max_{1 \leq k \leq NL} |X'_k(b)|$ . The set of allowed phase factors is written as

$$P = \{e^{j2\pi l/W} | l = 0, 1, \dots, W-1\} \quad (4)$$

where W is the number of allowed phase factors.

## III. Guided Scrambling

Guided scrambling is a line coding technique

developed specifically for high bit rate fiber optic transmission systems<sup>[7]</sup>. A straightforward implementation of GS is depicted in Fig. 2. The encoder views the source stream as a series of words  $m$  bits in length. Each word is augmented with  $r$  augmenting bits, resulting in an augmented word of length  $n$  where

$$n = m + r \quad (5)$$

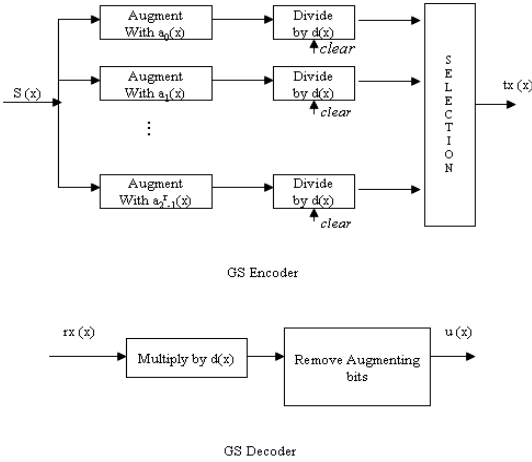

Fig. 2. Guided scrambling implementation

By augmenting the source word in the most significant positions with different augmenting bit values,  $2^r$  augmented bit streams are created. These augmented streams are simultaneously divided by  $d(x)$  to form  $2^r$  quotients. We call this collection of quotients the quotient selection set. The quotient with best line code characteristics is selected for transmission and the division registers are updated. Decoding is performed without delay through multiplication by  $d(x)$  and removal of bits from the augmenting bit positions.

#### IV. The Proposed Method

##### 4.1 Sub-Optimal PTS

The proposed Sub-Optimal PTS algorithm introduced the Hamming distance theoretic to increase the number of weighting factor explored and used the Multi-level structure to keep the optimal weighting factor that determined in every level<sup>[9, 10]</sup>. The proposed algorithm is described in detail as follows:

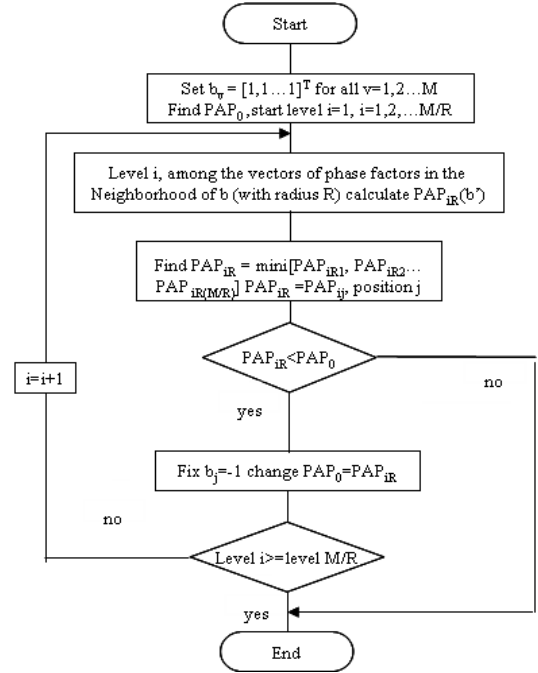

Fig. 3. The proposed weighting factor optimization method

At first, we can fixed the first weighting factor equal to 1 without any performance loss. For the first level process assume that  $b = b_v = 1$  for all  $v$  where  $b_v, v = 1, 2 \dots M$  are the weighting factor bits and compute the  $PAP_0$  of the combined signal. Then, from the second weighting factor, invert the  $R$  bits weighting factor to  $-1$  re-compute the resulting  $PAP_{iR1}$ , and store it. If  $PAP_{iR1}$  for  $b_{11}'$  is small than  $PAP_0$ , update  $b$  with  $b_{11}'$  and retain  $b_{11}'$  as part of the final weighting sequence and stop the optimization. If not, invert the other  $R$  bits weighting factor to  $-1$  re-compute the resulting  $PAP_{iR2}$ , and store it. If it is less than  $PAP_0$ , retain  $b_{12}'$  as part of the final weighting sequence and stop the optimization. The first level processing then continues in this fashion. Then the smallest  $PAP$  value among the first level processes,  $PAP_{i=1}$  is represented as

$$PAP_1 = PAP_{1j} = PAP_{1R} \quad (6)$$

$$= \min(PAP_{R1}, PAP_{R2}, \dots, PAP_{1R}(M/R))$$

where  $\min(\cdot)$  means the minimum value in the given expression and  $j$  stand for the  $R$  positions that have the smallest  $PAP$ .

Next, invert the weighting factors  $b_j = -1$ . If  $PAP_1$  is below  $PAP_0$ , change  $PAP_0$  to  $PAP_1$  and proceed to the second level, otherwise, stop the optimization. For the second level process, assume that  $b_v = 1$  for all  $m$ , except for the weighting factors ( $b_j = -1$ ) obtained in the first level processes, and invert the weighting factors ( $b_{2l}' = -1$ ) from the second bit  $b_2$  to the last bit  $b_M$  in the sequence, as the first level processes. After the last process is finished, the optimum weighting factors for the OFDM frame are given by

$$\{b_1', b_2' \dots b_M'\} = \min(PAP_1, PAP_2 \dots PAP_M) \quad (7)$$

#### 4.2 Combined with GS coding

In this section, we introduce the proposed Hybrid algorithm, which exhibits very good PAPR performance. The structure of the Hybrid approach is shown in Fig. 4. The input data block, represented by a vector  $X=[X_1, X_2, \dots, X_M]$ , is first partitioned into  $M$  disjoint subblocks  $\{X_M, M=1, 2, \dots, M\}$ . Each subblock  $X_M$  becomes the input to a signal selection set generation (SSSG) component shown in Fig. 5. Then, the outputs of the SSSG components are through the Sub-optimal PTS part to minimize the PAPR. Only one output sequence is selected from each component. The final OFDM signal is obtained by combing the selected output sequences. In the Hybrid scheme, we propose simply selecting the signal  $f_i(x)$  with the smallest value of

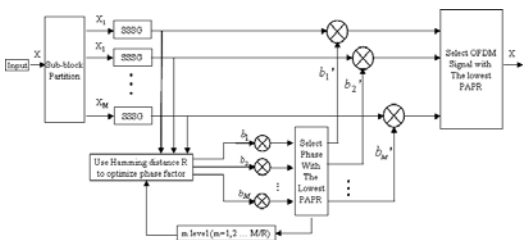

Fig. 4. Structure of Hybrid algorithm

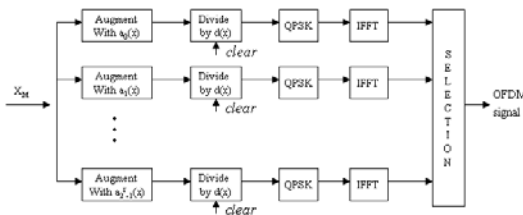

Fig. 5. Signal selection set generation (SSSG)

PAPR in each coding interval. However, to effectively reduce the PAPR of OFDM signals by Hybrid, there must be at least one signal in the set  $\{f_i(t), i=0, 1, \dots, 2^r-1\}$  which has a relatively small PAPR for each source word  $X_M$ . This requires a good mapping between source words and the signals in the selection set, which in turn implies appropriate selection of the Signal scrambling polynomial  $d(x)$ . In the<sup>[7]</sup>, we can know that, for  $r$  augmented bits, the polynomial  $d(x) = x^r+1$  can generate the good line code characteristics sequences. It is also shown that error extension in GS decoding is uniquely determined by the weight of the scrambling polynomial, and is less than or equal to this weight.

However, the scrambling polynomial of weight two results in relationship patterns with large PAPR. Considering of this rules, we propose searching for good scrambling polynomials from among those with low weight ( $\geq 3$ ).

### V. Results and Discussions

To evaluate and compare the performance of the new algorithm, computer simulation has been demonstrated. The parameters of simulation have been listed in Table 1.

Table 1. The system parameter

Parameter	Value
Number of random OFDM blocks	100,000
Number of subcarriers	128, 512
Number of subblock(M)	2, 4
Subblock Partitioning Scheme	Interleaving
Modulation scheme	QPSK
Phase factor	-1, 1
Scrambling Polynomial	$d(x)=X^4+X^3+1$
Augmented bits(r)	4

Fig. 6. (a) shows the CCDFs,  $Pr(PAP > PAP_0)$  for  $M=2$  and  $N=128$ . In this case, we can see that when  $M$  is small, the performance of the proposed Sub-Optimal methods are similar to the Cimini scheme<sup>[1]</sup>. But the proposed Hybrid schemes can get even 1.8dB performance gain

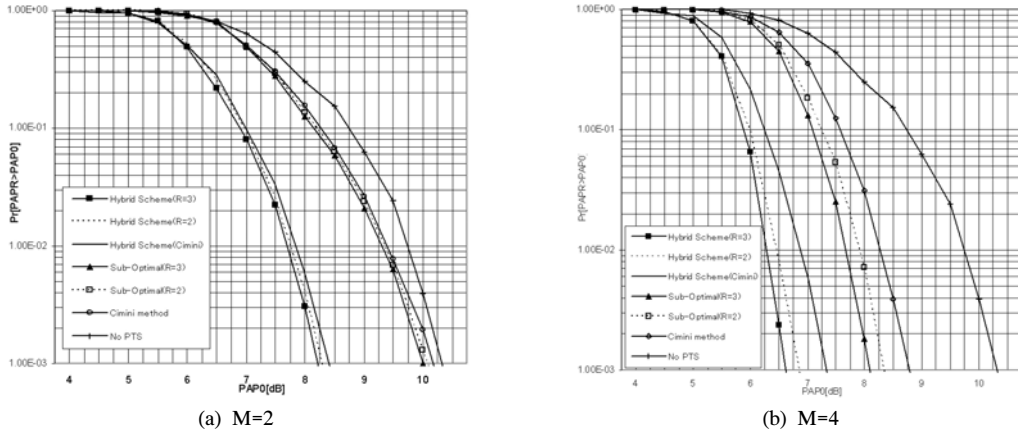

Fig. 6. CCDF of OFDM signal relative to QPSK constellation (N=128)

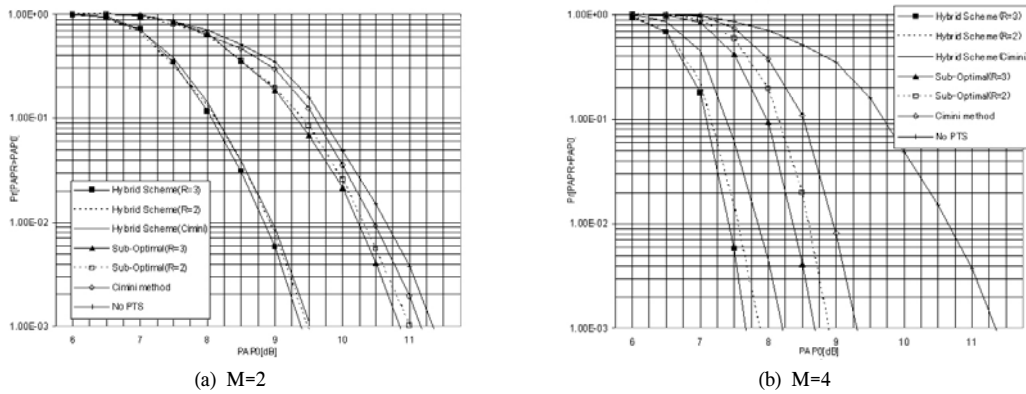

Fig. 7. CCDF of OFDM signal relative to QPSK constellation (N=512)

than the Cimini.

In the case of  $M=4$ , we can see from the Fig. 6. (b) that the 0.1% PAP of the Cimini method was 8.8 dB. The proposed Sub-Optimal scheme with  $R=2$  and  $R=3$  can improved it by 0.4dB and 0.6dB, respectively. Further more, the proposed Hybrid schemes can achieve 1.5dB gain compared to those schemes that have not added the guided scrambling.

From the Fig. 6, we found that, in the Hybrid, for a given  $d(x)$ , PAPR improves with an increase in number of subblocks  $M$ . It also indicates that use of Hybrid algorithm results in better PAPR performance than the Sub-Optimal PTS, especially when  $M$  is small. When we fixed the number of subblocks equal to 2, and increased the number of subcarriers to 512, we can observed from the Fig. 7 (a) that the proposed Sub-Optimal method

is also similar to the Cimini.

In addition, when  $M=4$  and  $N=512$ , from the Fig. 7 (b) that the proposed Sub-Optimal method is better than the Cimini scheme, can achieve 0.6dB gain at most. However, the Hybrid scheme can get 1.0dB gain than the Sub-Optimal scheme.

So, derived from the Fig. 7 that, when  $M$  is fixed, and increased the  $N$ , the performance gain because of the guided scrambling will be a little decrease.

Table 2 compares the computational complexities of the Hybrid-PTS, Hybrid-Cimini, and the proposed Hybrid schemes. From the table, we can see that the complexity of the proposed methods with  $R=2$  and  $R=3$  are 6.25% of the Hybrid-PTS.

In the case of  $M=4$ , the proposed Hybrid schemes with  $R=2$  and  $R=3$  can reduce the complexity to more than 96% and 93% of the GS-PTS. In the

Table 2. The Complexity of the optimization process

Augmented bits r	4		
No.of subblock	M	2	4
Hybrid scheme (ordinary PTS)	$2^{Mr}$	256	65536
Hybrid scheme (Cimini)	$M^r$	16	256
Hybrid scheme (R=2)	$[C_R^{(M-1)} + C_{(R-1)}^{(M-1)} + \dots + C_1^{(M-1)} + C_R^{(M-1-R)} + C_{(R-1)}^{(M-1-R)} + \dots + C_1^{(M-1-R)} + \dots + 1]^r$	16	2401
Hybrid scheme (R=3)	$[C_R^{(M-1)} + C_{(R-1)}^{(M-1)} + \dots + C_1^{(M-1)} + C_R^{(M-1-R)} + C_{(R-1)}^{(M-1-R)} + \dots + C_1^{(M-1-R)} + \dots + 1]^r$	16	4096

other hand, the proposed Hybrid methods are a little more complexity than the Hybrid-Cimini scheme, but with better performance in reduction of PAPR.

### VI. Conclusions

In this paper, the Hybrid scheme for reducing the PAPR is proposed. At first, we propose a Sub-Optimal PTS scheme to optimize the phase factor, which can get better performance than Cimini method. Then we integrate the Sub-Optimal PTS with guided scrambling, which is the proposed Hybrid method. From the simulation results, we can see that this scheme can get much gain in PAPR reduction. Moreover, Hybrid scheme don't need to transmit side information while incur little error extension during decoding and very small rate loss.

### REFERENCES

[1] L. J. Cimini, Jr. and N. R. Sollenberger, "Peak-to-average power ratio reduction of an OFDM signal using partial transmit sequence", IEEE Communications. Lett, vol. 4, no. 3, pp. 86-88, Mar. 2000.  
 [2] X. Li and L. J. Cimini, Jr., "Effect of clipping and filtering on the performance of

OFDM", IEEE Communications. Lett, vol. 2, no. 5, pp. 131-133, May 1998.  
 [3] A. E. Jones, T. A. Wilkinson, and S. K. Barton, "Block coding scheme for reduction of peak to mean envelope power ratio of multicarrier transmission scheme", IEEE Electronics Lett, vol. 32, no. 22, pp. 2098-2099, Dec. 1994.  
 [4] V. Tarokh and H. Jafarkhani, "On the computation and reduction of the peak-to-average power ratio in multicarrier communications", Communications, IEEE Transactions, vol. 48, no. 1, pp. 37-44, Jan. 2000.  
 [5] R. W. Baüml, R. F. H. Fischer, and J. B. Hüber, "Reducing the peak-to-average power ratio of multicarrier modulation by selective mapping", Electronics. Lett, vol. 32, no. 22, pp. 2056-2057, Oct. 1996.  
 [6] S. H. Muller and J. B. Hüber, "OFDM with reduced peak-to-average power ratio by optimum combination of partial transmit sequences", IEEE Electronics. Lett, vol. 33, no. 5, pp. 368-369, Feb. 1997.  
 [7] J. Fair Ivan, Wayne D. Grover, "Guided Scrambling: A new line coding technique for high bit rate fiber optic transmission systems", Communications, IEEE Transactions, vol. 39, no. 2, pp. 289-297, Feb. 1991.  
 [8] P. Van Eetvelt, G. Wade and M. Tomlinson, "Peak to average power reduction for OFDM schemes by selective scrambling", IEEE ELECTRONICS Lett, vol. 32, no. 21, pp. 1963-1964, Oct. 1996.  
 [9] S. H. Han, J. H. Lee, "Reduction of PAPR of an OFDM signal by partial transmit sequence technique with reduced complexity", IEEE Globecom, pp. 1326-1329, 2003.  
 [10] Oh-Ju Kwon and Yeong-Ho Ha, "Multi-carrier PAP reduction method using sub-optimal PTS with threshold", IEEE Transactions on Broadcasting, vol. 49, no. 2, pp. 232-236, June 2003.  
 [11] Zi-bin Zhao, Young Hwan Kim, Jae Moun Kim, "PAPR Reduction of an OFDM Signal Using Sub-Optimal PTS Combined with

Guided Scrambling,” IEEE ISCT 2005, Beijing, China, pp. 743~746.

조 자 빈 (Zi-Bin Zhao)

준회원

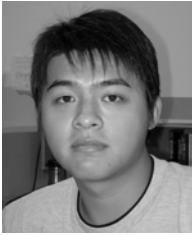

2004년 7월 베이징 공과대학 컴퓨터 공학과 졸업  
2004년 9월~현재 인하대학교 정보통신대학원 석사과정  
<관심분야> OFDM 시스템, 광대역 무선통신

김 영 환 (Young-Hwan Kim)

준회원

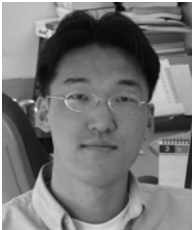

2004년 2월 인하대학교 전자공학과 졸업  
2004년 3월~현재 인하대학교 정보통신대학원 석사과정  
<관심분야> 이동통신, 광대역 무선통신

김 재 명 (Jaе-Moung Kim)

중신회원



1974년 2월 한양대학교 전자공학과 졸업  
1981년 8월 미국 남가주대학교 (USC) 전기공학과 졸업  
1987년 8월 연세대학교 전자공학과 졸업

1974년 3월~1979년 6월 한국과학기술연구소, 한국통신기술연구소 근무  
1982년 9월~2003년 3월 한국전자통신연구원 위성통신연구단 단장/무선방송연구소 소장 역임  
2003년 4월~현재 인하대학교 정보통신대학원 정교수, 한국방송공학회 부회장, 통신위성 우주산업연구회 회장 외 정부 및 다수기업에 기술자문 등으로 활동 중  
<관심분야> 광대역 무선전송, 이동통신 및 위성통신, 디지털 방송분야