

# Pump Light Power of Wideband Optical Phase Conjugator Dependence on Amplifier Spacing in 320 Gbps WDM Systems with MSSI

Seong-Real Lee\* *Regular Member*

## ABSTRACT

In this paper, the optimum pump light powers of optical phase conjugator(OPC) are numerically investigated as a function of amplifier spacing in 1,200 km 8×40 Gbps WDM systems with 0.1, 0.4, 0.8, or 1.6 ps/nm/km dispersion coefficient. It is confirmed that the variation of optimal pump light power dependence on amplifier spacing for NRZ transmission system is smaller than that for RZ transmission system through the evaluations and analysis of eye opening penalty(EOP) characteristics. And, in both cases of NRZ and RZ transmission, the variation of optimal pump light power is more increased as amplifier spacing becomes longer. Additionally, it is confirmed that the best amplifier spacing in NRZ and RZ transmission system is 50 km.

**key Words** : Optical phase conjugator(OPC), Highly-nonlinear dispersion shifted fiber(HNL-DSF), Optimal pump light power, Mid-span spectral inversion(MSSI), Amplifier spacing

## I. Introduction

High power optical amplifiers such as erbium-doped fiber amplifier(EDFA)<sup>[1]</sup> and dispersion management<sup>[2]</sup> enable increased length of inter-amplifier spans in multi-channel high bit-rate transmission systems. But the bit-rate-distance product is limited by the combined effects of fiber dispersion and nonlinear effects(namely, Kerr effect) due to the high launched power into the fiber<sup>[3],[4]</sup>. To overcome such limitations, mid-span spectral inversion(MSSI) using mid-way optical phase conjugator(OPC) was proposed<sup>[5]</sup>, and has now become one of the promising techniques as an alternative to the more-sophisticated soliton transmission system.

It was confirmed from the previous researches concern with MSSI that wideband WDM signals with excellent performance could be transmitted by using highly-nonlinear dispersion shifted fiber(HNL-DSF) instead of conventional DSF as a nonlinear medium of OPC<sup>[6],[7]</sup>. In those researches, it is possible to effectively compensate for overall distorted WDM channels belong to 3-dB bandwidth of OPC by

properly selecting pump light power that depend on total transmission length and fiber dispersion coefficient when an amplifier spacing is fixed to 50 km in 3 channels×40 Gbps WDM systems.

However the researches inducing the optimal pump light power of OPC depending on the amplifier spacing(namely, EDFA spacing) were not pronounced up to now. Thus, in this paper, the optimal pump light power of OPC is numerically induced as a function of amplifier spacing. And the compensation characteristics of distorted WDM signals at the induced optimal pump light power is also investigated, when OPC with HNL-DSF be placed at the mid-way of total transmission.

The considered WDM system has 8 channels of 40Gbps. The intensity modulation format is assumed to be NRZ, or RZ. The split-step Fourier method<sup>[8]</sup> is used for numerical simulation and eye-opening penalty(EOP) is used to evaluate the degree of compensation. In order to simplify the analysis, cross phase modulation(XPM) of inter-channels is neglected and four-wave mixing(FWM) can be suppressed by using unequal channel spacing scheme<sup>[9]</sup>.

\* Div. of Marine Electro. and Comm. Eng., Mokpo National Maritime University (reallee@mmu.ac.kr)  
논문번호 : KICS2006-04-178, 접수일자 : 2006년 4월 18일, 최종논문접수일자 : 2006년 8월 18일

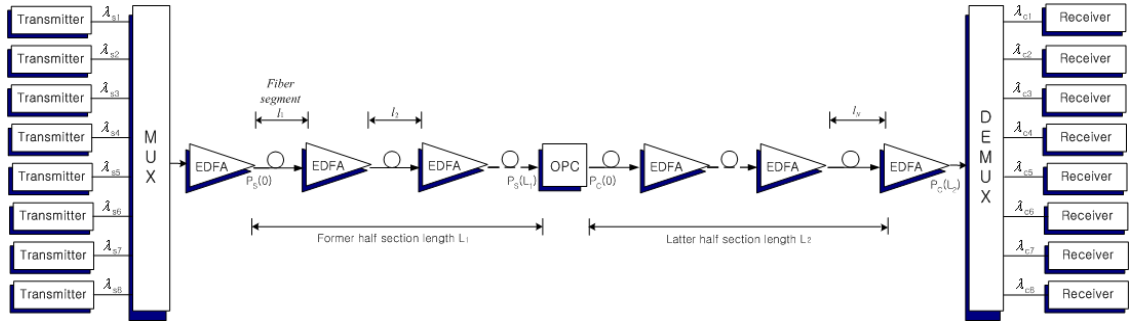

Fig. 1. Simulation model of 8x40 Gbps WDM system

II. Modeling of WDM system

Consider eight optical waves with the same polarization copropagating in an optical fiber. Let  $A_j(z, t)$  be the slowly varying complex field envelope of each wave normalized to make equal to the instantaneous optical power.  $A_j(z, t)$  satisfies the following equation<sup>[8]</sup> :

$$\frac{\partial A_j}{\partial z} = -\frac{\alpha}{2} A_j - \frac{i}{2} \beta_{2j} \frac{\partial^2 A_j}{\partial T^2} + \frac{1}{6} \beta_{3j} \frac{\partial^3 A_j}{\partial T^3} + i \chi_j |A_j|^2 A_j + 2 i \chi_j |A_k|^2 A_j$$

where  $j, k = 1, 2, \dots, 8(j \neq k)$ ,  $\alpha$  is the attenuation coefficient of the fiber,  $\lambda_j$  is the  $j$ -th channel signal wavelength,  $\beta_{2j}$  is the fiber chromatic dispersion parameter,  $\beta_{3j}$  is the third-order chromatic dispersion parameter,  $\chi_j$  is the nonlinear coefficient and  $T=t-z/v_j$ , respectively. The last two terms in equation (1) induce SPM and XPM, respectively. The last term, that is XPM term is neglected in order to simplify numerical analysis in this paper.

Fig. 1 shows a configuration of intensity modulation / direct detection(IM/DD) WDM system with OPC placed at mid-way of total transmission length. In Fig. 1, total transmission length( $L$ ) is assumed to be 1,200 km and this will be divided to several amplifier spans of respective length  $l_N$ , where  $N$  is assumed to be 12, 16, 24 and 30, respectively. Table 1 summarizes simulation parameters of transmitter<sup>[8]</sup>, receiver<sup>[10]</sup> and fiber, respectively.

Fig. 2 shows the configuration of the OPC using

Table 1. Simulation parameters of transmitter, fiber and receiver.

Parameters		Symbol & value
Transmitter	Bit rate	$R_b=320$ Gbps (=8x40 Gbps)
	Waveform	NRZ super-Gaussian(m=2) RZ super-Gaussian(m=2)
	Pattern	PRBS 2 <sup>7</sup> (128 bits)
	Chirp	0
Fiber	Type	conventional DSF
	Loss	$\alpha_1=\alpha_2=0.2$ dB/km
	Dispersion coefficient	$D=0.1, 0.4, 0.8, 1.6$ ps/nm/km
	Nonlinear refractive coefficient	$n_2=2.36 \times 10^{-26}$ km <sup>2</sup> /W
	Effective core area	$A_{eff}=50$ μm <sup>2</sup>
	Number of EDFA	Variable
EDFA spacing		$l=40,50, 75, 100$ km
Receiver	Type	PIN-PD
	EDFA noise figure	5 dB
	Optical bandwidth	1 nm
	Receiver bandwidth	$0.65 \times R_b$

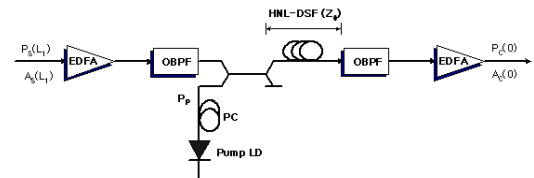

Fig. 2. Configuration of OPC using HNL-DSF

HNL-DSF, and Table 2 summarizes OPC parameters used in this approach. The conversion efficiency  $\eta$  is defined as a ratio of the four-wave mixing (FWM) product power to the input probe(signal) power<sup>[11]</sup>. Fig. 3 shows the calculated value of  $\eta$  using the parameters presented in table 2. The 3-dB bandwidth of  $\eta$  is 36nm(1532.5~1568.5nm), and that is independent on pump light power  $P_p$  of OPC.

Table 2. Simulation parameters of OPC using HNL-DSF.

Parameters	Symbol & value
Loss	$\alpha_0=0.61$ dB/km
Nonlinear coefficient	$\gamma_0=20.4$ W <sup>-1</sup> km <sup>-1</sup>
Length	$z_0=0.75$ km
Zero dispersion wavelength	$\lambda_0=1550.0$ nm
Dispersion slope	$dD_0/d\lambda= 0.032$ ps/nm <sup>2</sup> /km
Pump light wavelength	$\lambda_p=1549.5$ nm
Pump light power	$P_p=18.5$ dBm

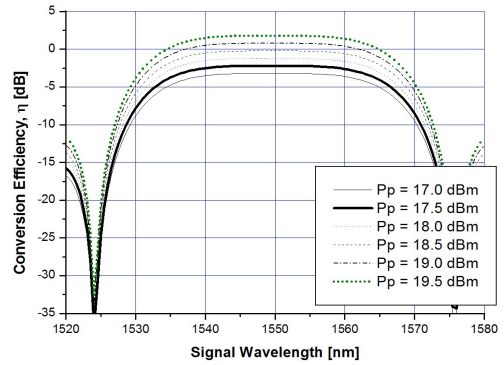
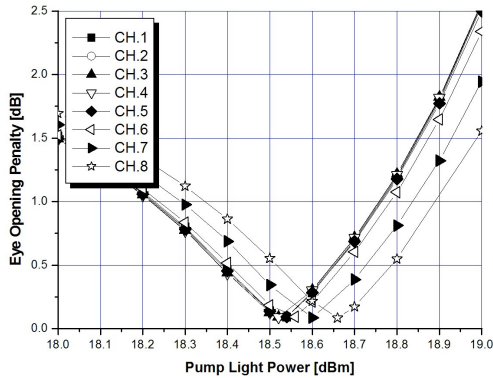
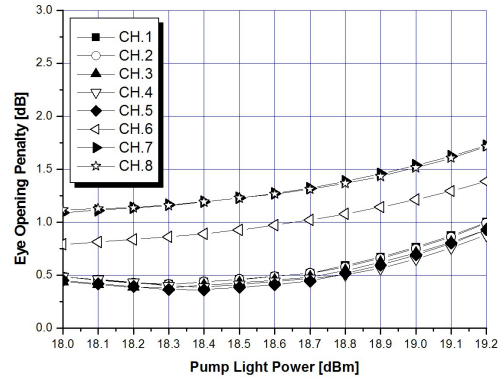

Fig. 3. The calculated value of conversion efficiency



(a)  $l=40$  km ;  $D=0.1$  ps/nm/km ; NRZ



(b)  $l=100$  km ;  $D=1.6$  ps/nm/km ; RZ

Fig. 4. EOP dependence on  $P_p$  in case of  $P_s=0$  dBm input light power of overall channels.

The unequal channel spacing proposed by F. Forghieri *et al.* is used to suppress the crosstalk due to FWM effects. The signal wavelengths of WDM channel used in this research are 1550.2, 1551.2, 1553.2, 1554.4, 1556.0, 1557.8, 1560.0 and 1561.4 nm. Therefore, WDM channel signal wavelengths and conjugated light wavelengths belong to 3-dB bandwidth of Fig. 3.

### III. Simulation results and discussion

#### 3.1 WDM channels EOP feature related with pump light power of OPC

Fig. 4 shows EOP of overall channels as a function of pump light power( $P_p$ ) of OPC when the input(launched) light powers( $P_s$ ) of overall channels are fixed to 0 dBm in two extreme cases with the large difference of amplifier spacing and dispersion coefficient such as  $l=40$  km and  $D=0.1$  ps/nm/km or  $l=100$ km and  $D=1.6$ ps/nm/km. An interesting fea-

ture of Fig. 4 is that EOP of six channels(channel 1~6) are similar with each other, but EOP of the residual channel(7 and 8) are different with those of the six channels. And those results are maintained irrespective of modulation format, amplifier spacing and fiber dispersion. This phenomenon is resulted from Fig. 3. That is,  $\eta$  of channel 7 and 8 is smaller than that of the others, although the signal and conjugated light wavelengths of these two channels belong to 3-dB bandwidth of  $\eta$ . Therefore, the evaluation of EOP characteristics dependence on pump light power fluctuation will be accomplished only about channel 1, 7 and 8 in following procedure.

#### 3.2 Investigation of pump light power in the case of fixing $P_s$ to 0 dBm

Fig. 5 shows EOP of NRZ channel 1, 7 and 8 at  $P_s=0$  dBm as a function of  $P_p$  in WDM transmission system with  $l=50$  km. The  $P_p$  of channel 1 resulting minimum EOP are 18.53, 18.46, 18.47

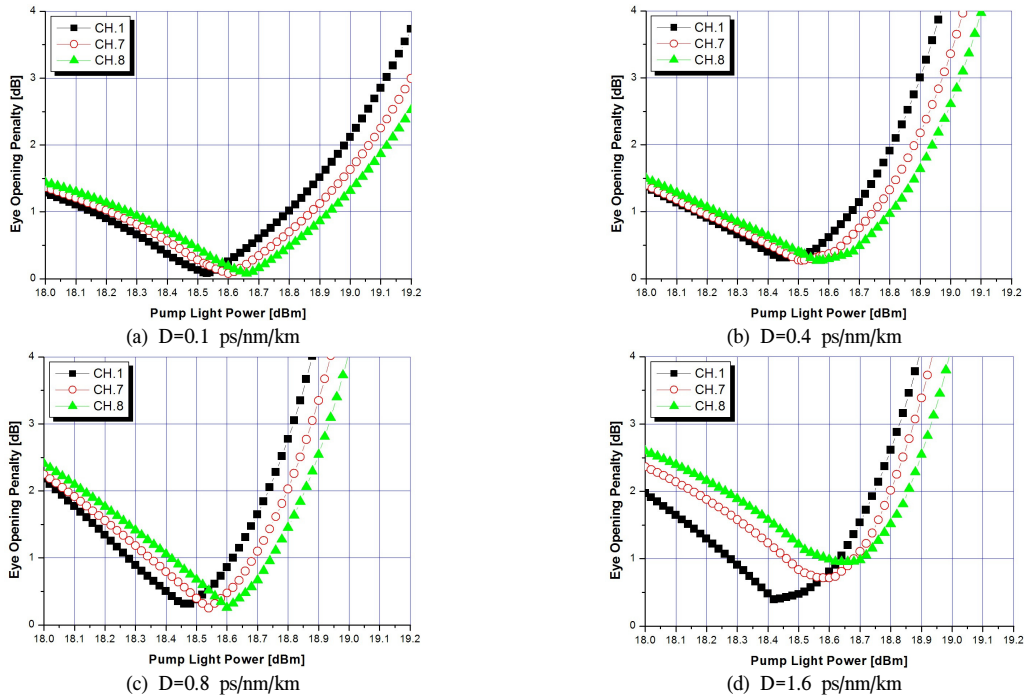

Fig. 5. EOP of NRZ channel 1, 7 and 8 with  $P_s=0$  dBm as a function of  $P_p$  in WDM system with  $l=50$  km.

Table 3. The pump light powers minimizing EOP in the case of assuming  $P_s$  to 0 dBm.

Modulation format	D [ps/nm/km]	$l$ [km]	$P_p$ minimizing channel 1's EOP	$P_p$ minimizing channel 8's EOP	$P_p$ simultaneously minimizing channel 1 and 8's EOP
NRZ	0.1	40	18.53	18.66	18.58
		50	18.53	18.66	18.58
		75	18.52	18.65	18.58
		100	18.51	18.64	18.56
	0.4	40	18.49	18.59	18.54
		50	18.46	18.57	18.52
		75	18.38	18.50	18.44
		100	18.30	18.44	18.34
	0.8	40	18.47	18.61	18.55
		50	18.47	18.60	18.54
		75	18.44	18.56	18.50
		100	18.40	18.50	18.44
	1.6	40	18.45	18.63	18.60
		50	18.43	18.67	18.62
		75	18.39	18.68	18.62
		100	18.24	18.49	18.70
RZ	0.1	40	18.54	18.67	18.59
		50	18.53	18.66	18.58
		75	18.46	18.58	18.52
		100	18.31	18.40	18.33
	0.4	40	18.56	18.69	18.56
		50	18.56	18.69	18.59
		75	18.66	18.74	18.66
		100	17.96	18.66	18.46
	0.8	40	18.54	18.68	18.63
		50	18.55	18.67	18.63
		75	18.55	18.79	18.64
		100	18.33	18.57	18.42
	1.6	40	18.52	18.54	18.54
		50	18.45	18.39	18.39
		75	18.21	17.95	17.95
		100	18.26	17.73	17.73

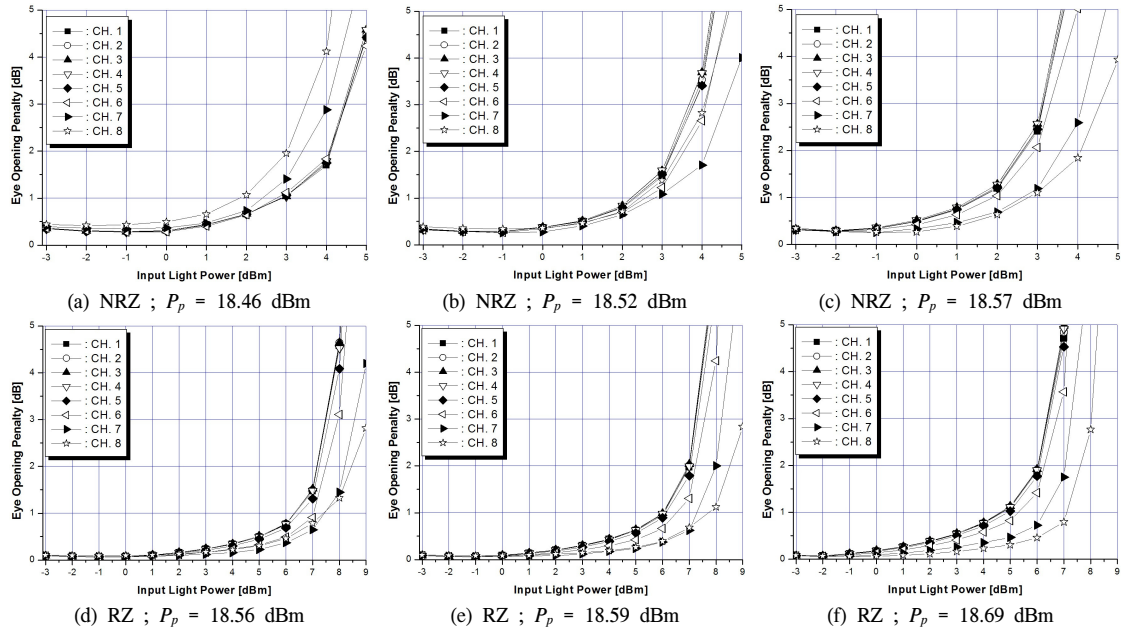

Fig. 6. EOP of overall NRZ and RZ channels as a function of the  $P_s$  at the  $P_p$  presented in Table 3 in the case of  $l=50$  km and  $D=0.4$  ps/nm/km.

and 18.43dBm in 0.1, 0.4, 0.8 and 1.6ps/nm/km, respectively. And, the  $P_p$  resulting minimum EOP are 18.66, 18.57, 18.60 and 18.67 dBm for channel 8, respectively. But, the  $P_p$  that simultaneously minimize EOP of channel 1, 7 and 8 are 18.58, 18.52, 18.54 and 18.62 dBm, respectively. Table 3 summarizes the  $P_p$  for all cases that simultaneously minimize EOP of overall channels. From Fig. 5 and Table 3, it is confirmed that the  $P_p$  resulting minimum EOPs is depend on modulation format, fiber dispersion, signal wavelength and amplifier spacing. Therefore, it is necessary to evaluate EOP characteristics of overall WDM channels at every pump light powers presented in Table 3 in order to search the optimal  $P_p$  depending on amplifier spacing and fiber dispersion.

Fig. 6 shows several examples of EOPs of overall NRZ and RZ channels as a function of the  $P_s$  at the  $P_p$  induced in Table 3, when  $l$  is 50km with  $D=0.4$  ps/nm/km. From Fig. 6 (a)~(c), it is confirmed that the excellent compensation for overall NRZ channels is properly obtained at  $P_p=18.52$  dBm, which simultaneously minimize EOP for channel 1, 7 and 8 as shown in Table 3. But, the different result is appeared for RZ channels(Fig. 6 (d)~(f)),

that is, the excellent compensation for overall RZ channels is obtained at  $P_p=18.56$  dBm, which minimize EOP for channel 1 as shown in Table 3. These two results mean that it is not easy to select the optimal  $P_p$  depending on modulation format, fiber dispersion and amplifier spacing. The limitation of searching for the optimal  $P_p$  using Table 3 is the assuming  $P_s$  to 0 dBm for all cases. If 1 dB EOP is allowed for performance criterion,  $P_s$  that result 1 dB EOP are changed by modulation format, fiber dispersion and amplifier spacing as shown in Fig. 6. Therefore, the accurately optimal  $P_p$  have to be searched at the various  $P_s$  resulting 1 dB EOP depending on modulation format, fiber dispersion and amplifier spacing.

### 3.3 Investigation of pump light power in the cases of various $P_s$

Fig. 7 shows EOP of NRZ channel 1, 7 and 8 as a function of the  $P_p$  at the appropriately selected  $P_s$  that result 1 dB EOP for the case of  $l=50$  km. By comparing Fig. 7 with Fig. 5, it is confirmed that the  $P_p$  of each channel that minimize EOP are changed by setting the criterion of  $P_s$ . Table 4 summarizes the  $P_p$  that minimize EOP at the  $P_s$

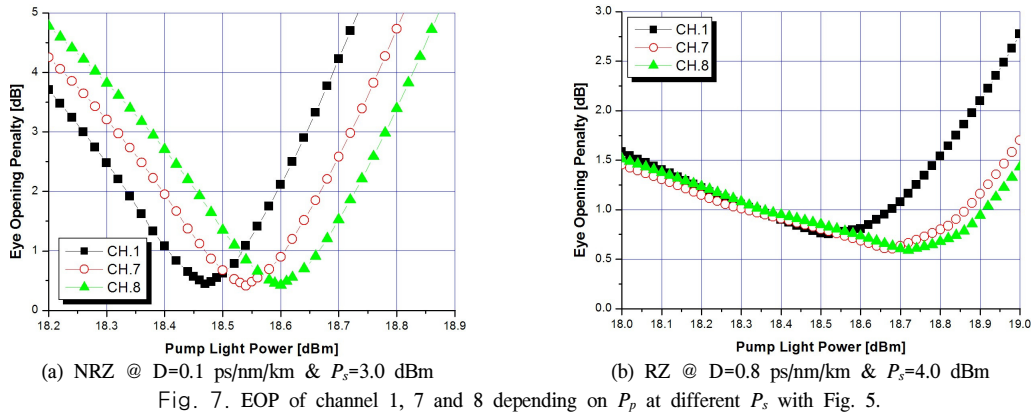

Fig. 7. EOP of channel 1, 7 and 8 depending on  $P_p$  at different  $P_s$  with Fig. 5.

Table 4. The pump light powers minimizing EOP at various  $P_s$ .

Modulation format	D [ps/nm/km]	$l$ [km]	$P_p$ minimizing channel 1's EOP	$P_p$ minimizing channel 8's EOP	$P_p$ simultaneously minimizing channel 1 and 8's EOP	$P_s$ [dBm]
NRZ	0.1	40	18.49	18.62	18.55	3.0
		50	18.47	18.60	18.53	
		75	18.42	18.55	18.48	
		100	18.38	18.51	18.44	
	0.4	40	18.48	18.62	18.52	2.5
		50	18.48	18.61	18.52	
		75	18.34	18.46	18.42	
		100	18.24	18.36	18.30	
	0.8	40	18.46	18.60	18.55	1.7
		50	18.46	18.59	18.53	
		75	18.40	18.56	18.49	
		100	18.34	18.50	18.44	
	1.6	40	18.46	18.62	18.57	1.0
		50	18.46	18.65	18.58	
		75	18.40	18.63	18.55	
		100	18.29	18.55	18.55	
RZ	0.1	40	18.78	18.63	18.70	6.0
		50	18.80	18.60	18.69	
		75	18.92	18.48	18.72	
		100	18.70	18.94	18.80	
	0.4	40	18.48	18.66	18.50	6.0
		50	18.50	18.64	18.50	
		75	18.52	18.70	18.54	
		100	18.24	18.62	18.24	
	0.8	40	18.52	18.64	18.58	4.0
		50	18.51	18.62	18.56	
		75	18.52	18.72	18.56	
		100	18.34	18.52	18.32	
	1.6	40	18.54	18.62	18.90	3.0
		50	18.46	18.48	18.90	
		75	18.28	18.28	19.05	
		100	18.30	18.22	19.20	

resulting 1 dB EOP in all cases. Hereafter, the EOP characteristics of overall WDM channels at the  $P_p$  presented in Table 4 will be evaluated and then compared with the EOP characteristics at the  $P_p$  presented in Table 3 in order to search the optimal  $P_p$  depending on amplifier spacing and fiber dispersion.

Fig. 8 and 9 show EOPs of overall NRZ and RZ channels as a function of the  $P_s$ , respectively, when

$l$  is 40 km in case of NRZ transmission and 75 km in case of RZ transmission. In each figure, the left side graphs and the right side graphs are the best cases among EOPs simulated at the pump light power that are shown in Table 3, and 4, respectively. As shown in Fig. 8 and 9, for NRZ transmission the optimal  $P_p$  are 18.55, 18.52, 18.55 and 18.63 dBm, also for RZ transmission the optimal  $P_p$  are 18.45, 18.54, 18.56 and 17.95 dBm respectively,

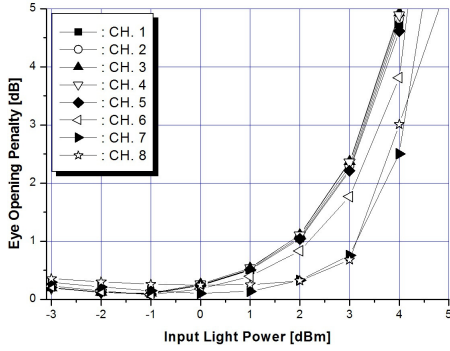

(a)  $D=0.1$  ps/nm/km ;  $P_p=18.58$  dBm

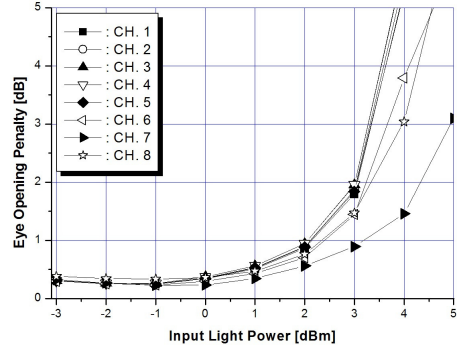

(b)  $D=0.4$  ps/nm/km ;  $P_p=18.54$  dBm

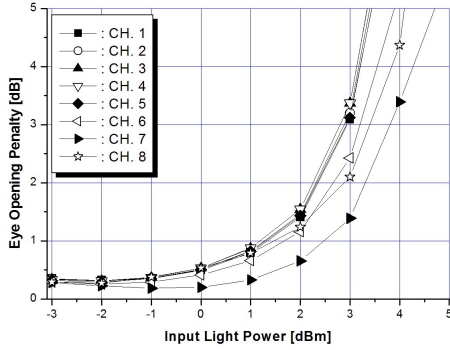

(c)  $D=0.8$  ps/nm/km ;  $P_p=18.55$  dBm

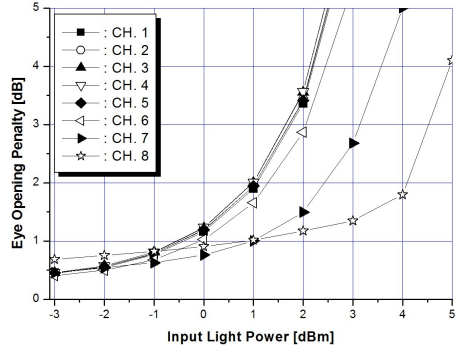

(d)  $D=1.6$  ps/nm/km ;  $P_p=18.63$  dBm

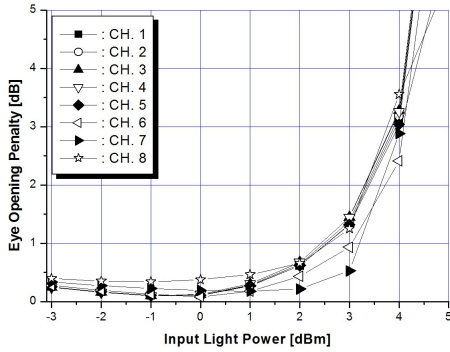

(e)  $D=0.1$  ps/nm/km ;  $P_p=18.55$  dBm

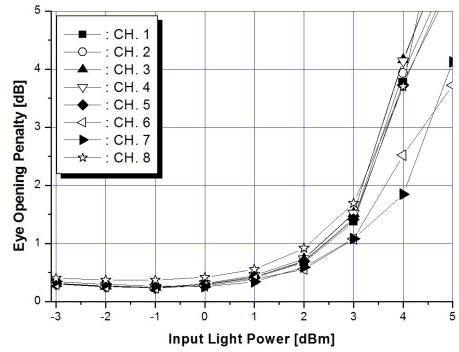

(f)  $D=0.4$  ps/nm/km ;  $P_p=18.52$  dBm

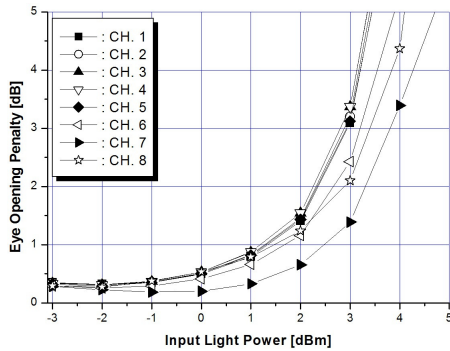

(g)  $D=0.8$  ps/nm/km ;  $P_p=18.55$  dBm

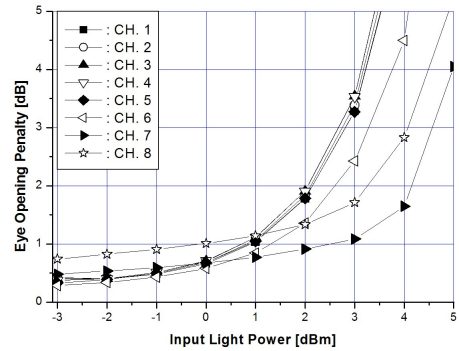

(h)  $D=1.6$  ps/nm/km ;  $P_p=18.57$  dBm

Fig. 8. The best cases of EOP for overall NRZ channels at  $P_p$  presented in Table 3 (left side figures) and 4 (right side figures), respectively, as a function of  $P_s$  in the case of  $l=40$  km.

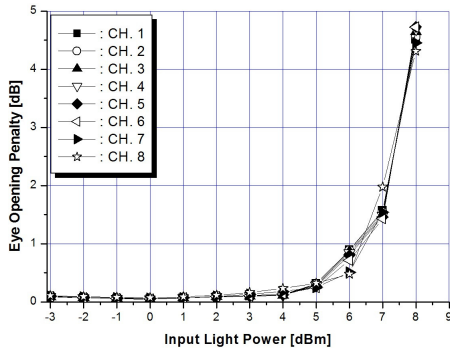

(a)  $D=0.1$  ps/nm/km ;  $P_p=18.45$  dBm

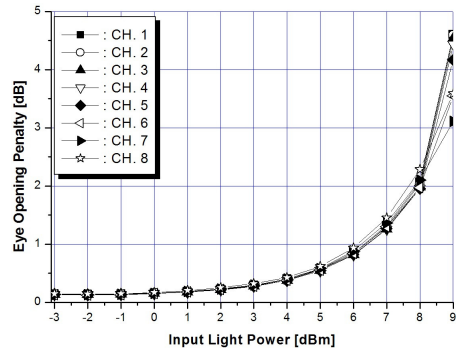

(b)  $D=0.4$  ps/nm/km ;  $P_p=18.42$  dBm

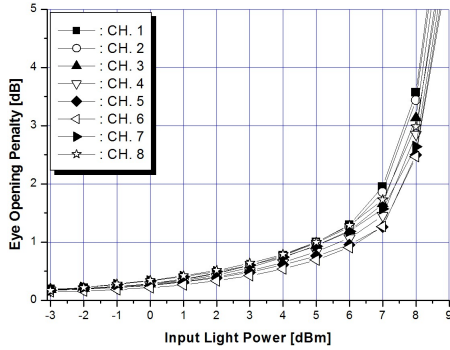

(c)  $D=0.8$  ps/nm/km ;  $P_p=18.55$  dBm

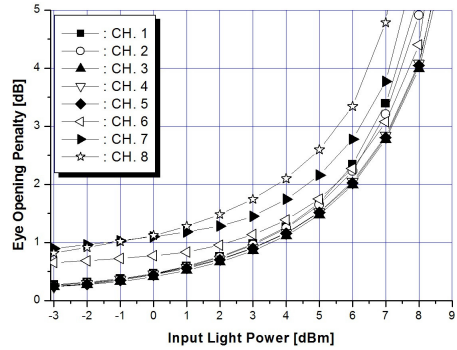

(d)  $D=1.6$  ps/nm/km ;  $P_p=17.95$  dBm

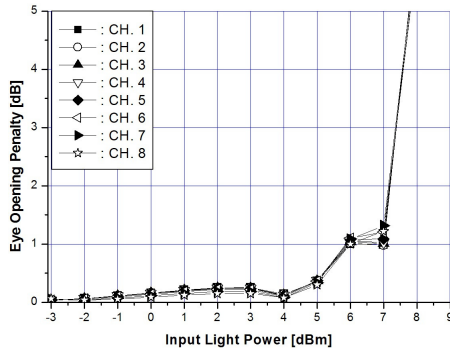

(e)  $D=0.1$  ps/nm/km ;  $P_p=18.72$  dBm

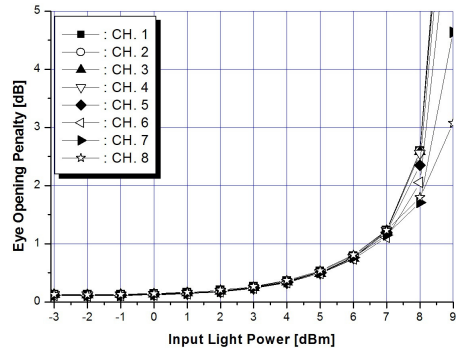

(f)  $D=0.4$  ps/nm/km ;  $P_p=18.54$  dBm

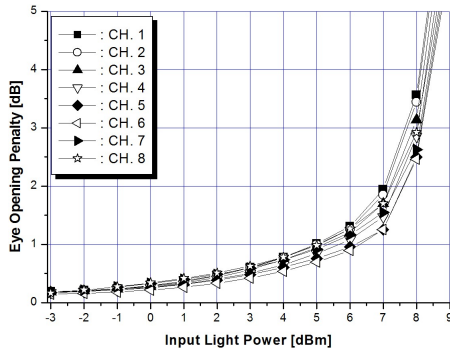

(g)  $D=0.8$  ps/nm/km ;  $P_p=18.56$  dBm

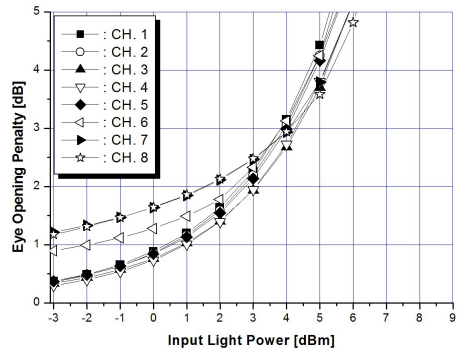

(h)  $D=1.6$  ps/nm/km ;  $P_p=19.05$  dBm

Fig. 9. The best cases of EOP for overall RZ channels at  $P_p$  presented in Table 3 (left side figures) and 4 (right side figures), respectively, as a function of  $P_s$  in the case of  $l=75$  km.



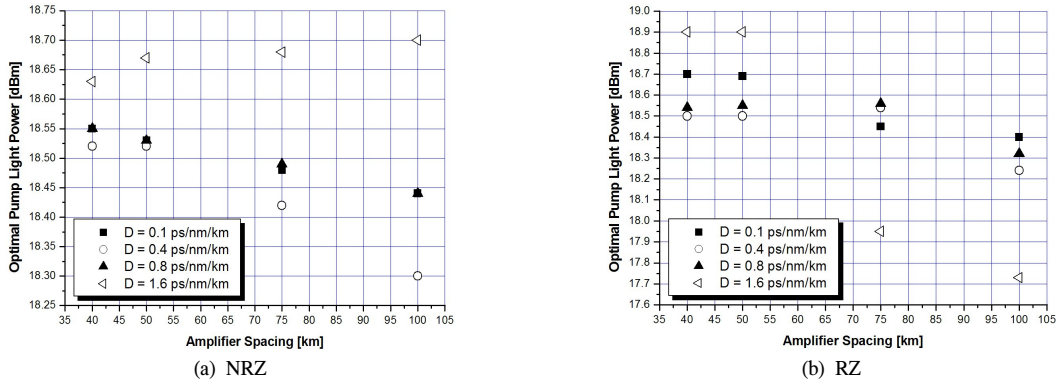

Fig. 10. The optimal  $P_p$  for NRZ transmission and RZ transmission as a function of amplifier spacing, respectively.

as fiber dispersion becomes increased.

### 3.4 Inducing of optimal pump light power

Fig. 10 shows the optimal  $P_p$  as a function of amplifier spacing in NRZ and RZ transmission, respectively. The markers plotted in Fig. 10 are obtained from the similar procedure in Fig. 8 and 9. As shown in Fig. 10, for NRZ transmission system the variation of the optimal  $P_p$  depending on amplifier spacing is smaller than that for RZ transmission system. And, in both cases of NRZ and RZ transmission, the variation of the optimal  $P_p$  is more increased as amplifier spacing becomes longer. But, if amplifier spacing becomes shorter than 50 km, the variation of the optimal  $P_p$  depending on fiber dispersion relatively small.

This feature is resulted from that the long amplifier spacing less affects the transmitting WDM signal distortion than the short amplifier spacing when the other transmission conditions are same with each other. This phenomenon is generated by following reason. The intensity of WDM signal is decreased as amplifier spacing becomes longer. Consequently, the transfer of intensity modulation into phase modulation is less generated in the long amplifier spacing system than the short amplifier spacing system. Therefore, the best amplifier spacing in NRZ and RZ transmission system is 50 km.

## IV. Conclusion

Up to now the optimal pump light power of OPC as a function of the amplifier spacing was numerically

induced in WDM system with 0.1, 0.4, 0.8 and 1.6 ps/nm/km fiber dispersion, respectively. And the best amplifier spacing that results the excellent compensation was investigated from a viewpoint of the variation of the optimal pump light power depending on fiber dispersion.

It was confirmed that the variation of the optimal pump light power is more increased as amplifier spacing becomes longer in both cases of NRZ and RZ transmission, but this variation is smaller in NRZ transmission than RZ transmission. Also, the best amplifier spacing in NRZ and RZ transmission system is 50 km.

The optimal pump light power exactly induced in this research is not always just in WDM system with 1,200 km total transmission length because the problem of method. That is, the optimal pump light power can be altered by the arbitrarily launched power. But, in this paper, the proposed method to searching for optimal pump light power should has availability for multichannel transmission system such as long-haul WDM with a lot of amplifiers.

## References

- [1] D. Marcuse, "Single-channel operation in very long nonlinear fibers with optical amplifiers at zero dispersion", *J. Lightwave Technol.*, Vol. LT-8, No.10, pp.1548-1557, 1990.
- [2] A. M. Vengsakar, W. A. Reed, "Dispersion-compensating single-mode fibers : Efficient designs for first- and second-order compensation",

- Opt. Lett.*, Vol.18, pp.924-926, 1993.
- [3] N. Shibata, K. Nosu, K. Iwashita and Y. Azuma, "Transmission limitations due to fiber nonlinearities in optical FDM systems", *IEEE J Select. Areas in Comm.*, Vol.8, No.6, pp. 1068~1077, 1990.
- [4] A. R. Chraplyvy, Limitations on lightwave communications imposed by optical-fiber nonlinearities, *J. Lightwave Technol.*, Vol.8, No.10, pp.1548~1557, 1990
- [5] S. Watanabe and M. Shirasaki, "Exact compensation for both chromatic dispersion and Kerr effect in a transmission fiber using optical phase conjugation", *J. Lightwave Technol.*, Vol.LT-14, No.3, pp.243~248, 1996.
- [6] Seong-Real Lee and S. E. Cho, Pump light power of optical phase conjugator using HNL-DSF in WDM systems with MSSSI, *The J. of Korean Inst. of Comm. Sciences*, Vol.30, No.3A, pp.168~177, 2005.
- [7] Seong-Real Lee and S. E. Cho, The compensation characteristics of WDM channel distortion dependence on NRZ format and RZ format, *The J. of the Korea Electromag. Eng. Soc.(Korean)*, Vol.14, No.11, pp.1184~1190, 2003.
- [8] G. P. Agrawal, *Nonlinear Fiber Optics*, Academic Press, 2001.
- [9] F. Forghieri, R. W. Tkach and A. R. Chraplyvy, "WDM systems with unequally spaced channels", *J. Lightwave Technol.*, Vol.LT-13, No.5, pp.889~897, 1995.
- [10] G. P. Agrawal, *Fiber-optic communication systems*, John Wiley & Sons, Inc., 2002.
- [11] K. Inoue, "Four-wave mixing in an optical fiber in the zero-dispersion wavelength region", *J. Lightwave Technol.*, Vol.LT-10, No.11, pp.1553~1561, 1992.

**Seong-Real Lee**

Regular member



received the B.S., M.S. and Ph. D. degree in telecommunication and information engineering from Hankuk Aviation University, Korea in 1990, 1992 and 2002, respectively. He was a senior engineer at R&D center of Seyoung Co.,

Ltd. from January 1996 to June 2002, and CTO at R&D center of ATN Co., Ltd. from June 2002 to February 2004. He is currently an assistant professor at the Division of Marine Electronic and Communication Eng., Mokpo National Maritime University. His research interest include optical WDM systems, optical soliton systems and the optical nonlinear effects.