

Compensation for the Distorted 16×40 Gbps NRZ Channels in 1,000 km NZ-DSF WDM System Using MSSSI with Optimal Parameters

Seong-Real Lee* *Regular Member*

ABSTRACT

In this paper, the optimum position of optical phase conjugator (OPC) and the optimal dispersion coefficients of fiber sections in WDM system with the conventional mid-span spectral inversion (MSSSI) are numerically induced and then applied into 16×40 Gbps WDM systems with 1,000 km non zero - dispersion shifted fiber (NZ-DSF) in order to efficiently compensate for the distorted overall channels. It is confirmed that the compensation extents of overall WDM channels are more improved by applying the induced optimal parameters into WDM system than those in WDM system with the conventional MSSSI. So it is expected to alternate with the forming method of the symmetrical distributions of power and local dispersion by applying these optimal parameters into the real WDM system, which generate a serious problem of applying the OPC into multi-channels WDM system if it is not formed. It is also confirmed that two optimal parameters depend on each other, but less related with the finding procedure. And, it will be possible to realize the flexible system design by applying the methods proposed in this paper into the real WDM system with OPC.

key Words : Optical phase conjugator(OPC), Mid-span spectral inversion(MSSSI), Optimal parameters, NZ-DSF, WDM

I . Introduction

Wavelength division multiplexing (WDM) techniques are realizing the broadband networks by offering ultra wide bandwidth. However, WDM systems also give rise to the signal distortion by chromatic dispersion and undesirable nonlinear effects such as self phase modulation (SPM), cross phase modulation (XPM) and four-wave mixing (XPM), when multi-channels are copropagated through the same fiber^[1].

Since the 10 Gbps optical transmission systems were realized, dispersion shifted fiber (DSF) instead of conventional single mode fiber (SMF) is widely used in order to overcome the distortion of signal due to chromatic dispersion in optical fiber. But the serious crosstalk owing to FWM is appeared in multi-channels transmission system using DSF as the transmission lines, con-

sequently the problem should be generated in the case of expanding that system to WDM system. In mostly recent, the fiber overcoming the problems of DSF is developed for realizing multi-channel WDM system. The zero dispersion wavelength of this new type fiber is appeared beyond transmission bandwidth and the chromatic dispersion of this fiber is relatively large, because FWM effect is more decreased as the chromatic dispersion is larger^[2]. This fiber is called to non zero - DSF (NZ-DSF).

But, even if NZ-DSF is used to suppress FWM effect, the bit-rate distance product in long-haul WDM system with erbium doped fiber amplifier (EDFA) is limited by SPM and XPM effects, which are generated owing to high power of optical signal in EDFA^[3]. One of the techniques to overcome this limitation is mid-span spectral inversion (MSSSI). Theoretically, this technique overcomes both SPM effect and dispersive effects by using

* Div. of Marine Electro. and Comm. Eng., Mokpo National Maritime University (reallee@mmu.ac.kr)
논문번호 : KICS2006-08-343, 접수일자 : 2006년 8월 10일, 최종논문접수일자 : 2006년 11월 16일

optical phase conjugator (OPC) for compensating distorted signals in mid-way of total transmission length^[4].

The serious problems have to be solved in order to apply this technique into WDM system. The first problem is that a perfectly symmetrical distribution of power and local dispersion with respect to OPC position is formed for nonlinearity cancellation in real transmission links^[5]. The second is that the OPC must exhibit the similar conversion efficiency over large bandwidth for increasing number of WDM channels. Fortunately, the second problem is solved by using highly-nonlinear dispersion shifted fiber (HNL-DSF) as a nonlinear medium of OPC because the effective bandwidth of HNL-DSF is wide and flattened^[6]. But, the first problem still remains in the perfectly compensating the distorted overall WDM channels. Furthermore it is very difficult to obtain the solution simultaneously applying the total transmitting channels, because the WDM channels copropagating in an optical fiber have different wavelengths, even if this problem was solved for a special wavelength. Thus it is-require to research the new method, which is able to alternate with method for solving the mentioned first problem, for implementing OPC in the real WDM systems.

This research focus on the method that has the effect of alternating with the forming method of the symmetrical distributions mentioned in previous. This paper is first devoted to numerically searching the optimal OPC position and the optimal dispersion coefficients of fibers which are compensating for the distortion of overall channels to similar performance, without the making the symmetrical distributions. The effectiveness of these optimal parameters is numerically verified on the comparison of the compensation characteristics in WDM system with the induced optimal parameters and in WDM system with conventional MSSSI technique.

The considered WDM system has 16channels of 40 Gbps. The intensity modulation format is assumed to be

NRZ. The split-step Fourier method^[7] is used for numerical simulation. The evaluation parameters for compensation degree are eye-opening penalty (EOP) of each channel. XPM effect of inter-channels is neglected in order to simplify the analysis.

II. Modeling of WDM system

Consider 16 optical waves with the same polarization copropagating in an optical fiber. Let $A_j(z, t)$ be the slowly varying complex field envelope of each wave normalized to make equal to the instantaneous optical power. $A_j(z, t)$ satisfies the following equation^[7] :

$$\begin{aligned} \frac{\partial A_j}{\partial z} = & -\frac{\alpha}{2} A_j - \frac{i}{2} \beta_{2j} \frac{\partial^2 A_j}{\partial T^2} \\ & + \frac{1}{6} \beta_{3j} \frac{\partial^3 A_j}{\partial T^3} + i \chi_j |A_j|^2 A_j \\ & + 2 i \chi_j |A_k|^2 A_j \end{aligned} \quad (1)$$

where $j, k = 1, 2, \dots, 16(j \neq k)$, α is the attenuation coefficient of the fiber, λ_j is the j -th channel signal wavelength, β_{2j} is the fiber chromatic dispersion parameter, β_{3j} is the third-order chromatic dispersion parameter, χ_j is the nonlinear coefficient and $T=t-z/v_j$, respectively. The last two terms in equation (1) induce SPM and XPM, respectively.

Fig. 1 shows a configuration of intensity modulation / direct detection (IM/DD) WDM system with OPC placed at mid-way of total transmission length. In Fig. 1, total transmission length (L) is divided two sections of respective length L_1 and L_2 (with $L = L_1+L_2$) and each fiber section consist of 10 amplifier spans of length $l = 50$ km. Fiber parameters assumed for analysis and numerical simulations throughout this paper are summarized in Table 1^[8]. The effects of XPM on WDM signals are more decreased as the fiber dispersion is larger^[9]. XPM

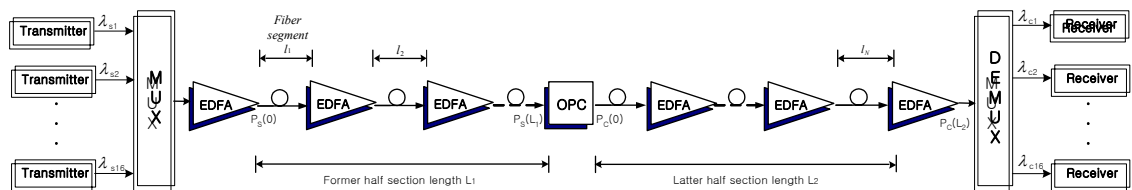

Fig. 1. Simulation model of 16×40 Gbps WDM system

effect of inter-channels is neglected in order to simplify the analysis in this research. Because the dispersion coefficients of fiber in this research are assumed to be 2 or 4ps/nm/km, which less affect the signal distortions due to XPM.

Table. 1. Fiber parameter assumptions.

Parameter	Symbol & Value
Type	NZ-DSF
Chromatic dispersion	$D_{1x} = 2, 4 \text{ ps/nm/km}$
Nonlinear refractive index	$n_2 = 2.5 \times 10^{-20} \text{ m}^2/\text{W}$
Attenuation	$\alpha = 0.2 \text{ dB/km}$
Effective core area	$A_{\text{eff}} = 72 \text{ }\mu\text{m}^2$

Watanabe and Shirasaki generalized the MSSI by considering that above fiber parameters can be functions of distance z ^[5]. The general condition for perfect distortion compensation is shown to be

$$\frac{\beta_2(-z_1')}{P(-z_1')\gamma_f(-z_1')} = \frac{\beta_2(z_2')}{P(z_2')\gamma_f(z_2')} \quad (2)$$

This relation means that perfect distortion compensation can be obtained by providing the equal ratio of the dispersion and nonlinearity at the corresponding positions $-z_1'$ and z_2' . That is, the OPC need not be placed at the mid-way of total transmission length and dispersion coefficient of latter half section need not equal with that of former half section which are dependent on the signal wavelength. However, the equation (2) also means that it is not easy to find out the common OPC position and

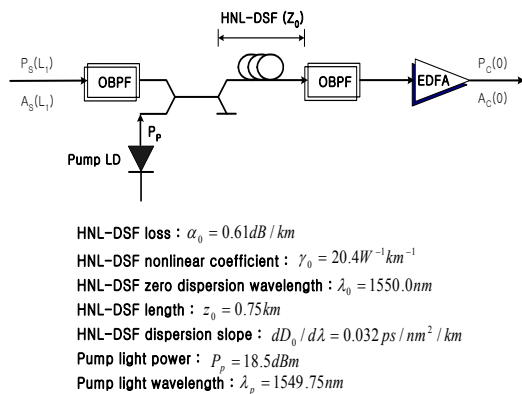

Fig. 2. OPC using HNL-DSF.

dispersion coefficient of each fiber sections available for total allocated WDM wavelengths in real transmission link, because equation (2) is dependent on the wavelength. Thus, this research is devoted to find out the optimal OPC position and dispersion coefficient of each fiber sections, which are simultaneously available for 16 WDM channels.

The optimal OPC position is found out by evaluating the compensation characteristics for special WDM channels as a function of the OPC position (z_{OPC}) varied within one span length ($\pm 25 \text{ km}$) from the mid-way (z_{mid}). The difference between z_{OPC} and z_{mid} i.e., $z_{OPC} - z_{mid}$ is called to the OPC position offset, Δz . And the optimal dispersion coefficient of each section Δ is also found out by evaluating the compensation characteristics as a function of dispersion offset, $D_{1x} (x = 1, 2)$. The dispersion offset is defined to difference of dispersion coefficient between two fiber sections, i.e., $\Delta D_{11} = D_{11} - D_{12}$ and $\Delta D_{12} = D_{12} - D_{11}$.

Each laser diode in transmitter of Fig. 1 is externally modulated by an independent 40 Gbps $128(=2^7)$ pseudo random bit sequence (PRBS). And output electric field of NRZ format signal from external optical modulator is assumed to be second-order super-Gaussian pulse. The direct detection receiver of Fig. 1 consist of the pre-amplifier of EDFA with 5 dB noise figure, the optical filter of 1 nm bandwidth, PIN diode, pulse shaping filter (Butterworth filter) and the decision circuit^[9]. The receiver bandwidth is assumed to be $0.65 \times \text{bit-rate}$.

Fig. 2 shows the configuration of the OPC using HNL-DSF, and its parameters. The conversion efficiency η is defined as a ratio of the four-wave mixing

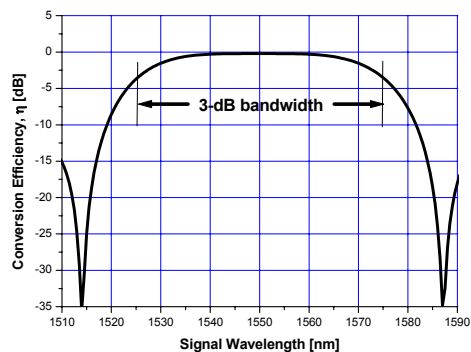

Fig. 3. The conversion efficiency value

(FWM) product power to the input probe (signal) power^[10]. The 3-dB bandwidth of η of the OPC shown in Fig. 2 is obtained to 48 nm (1526~1574 nm) as shown in Fig. 3.

The center wavelengths of WDM channels are allocated by equally spacing scheme as ITU-T recommendation in this research. ITU-T recommends that the channel spacing for dense WDM includes 100 GHz (that is 0.8 nm)^[11]. The center wavelength of first channel is assumed to be 1550.0 nm in this research. Thus the allocated 16 wavelengths (that is, from 1550.0 nm to 1562.0 nm) are within 3-dB bandwidth of Fig. 3.

III. Simulation results and discussion

Fig. 4 shows eye opening penalty (EOP) of channel 1 and 16, the wavelength difference of these channels is most, as a function of pump light power of OPC when the input (launching) powers of each channel are fixed to 0 dBm. From Fig. 4, the optimal pump light power is obtained to be 18.5 dBm.

Fig. 5 shows EOP of overall channels as a function

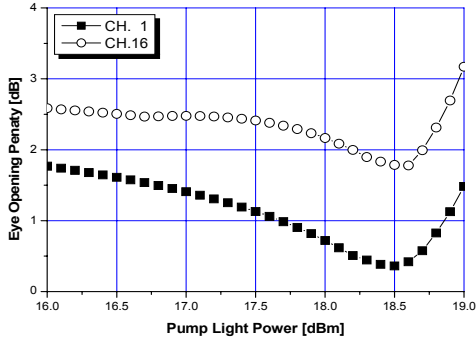
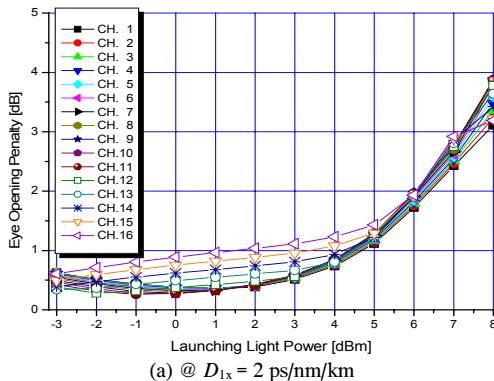

Fig. 4. EOP as a function of pump light power.



(a) @ $D_{1x} = 2$ ps/nm/km

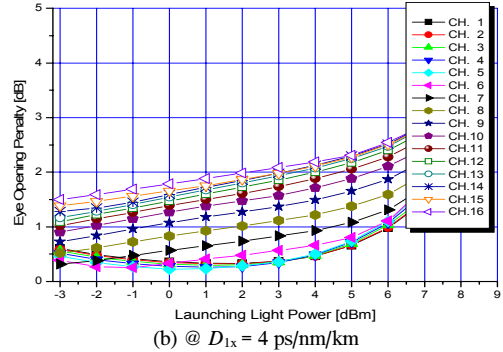

Fig. 5. EOP as a function of the launching power in WDM system with MSSI.

of the launching power when OPC placed at mid-way of total transmission length and $\Delta D_{1x} = 0$ ps/nm/km (that is, conventional MSSI). It is shown that EOPs are more degraded as the signal wavelengths are more deviated from the zero dispersion wavelength of HNL-DSF OPC. Furthermore, this degradation is more intensified as the dispersion coefficient of fiber is larger. Thus, it is restrict to expand channel numbers in directly applying MSSI into WDM systems.

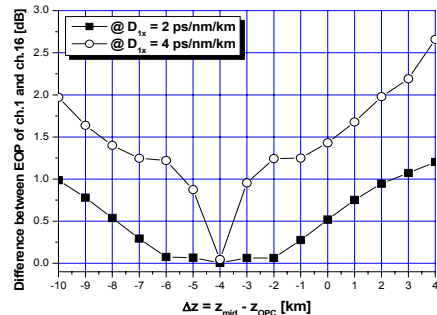

Fig. 6. EOP differences as a function of Δz for $\Delta D_{1x} = 0$ ps/nm/km.

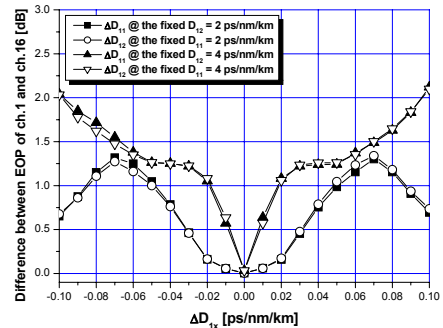

Fig. 7. EOP differences as a function of ΔD_{1x} when the OPC placed at Δz .

Fig. 6 shows EOP difference between channel 1 and 16 depending on the OPC position offset, Δz in order to find out the best OPC position. If WDM channels had the relatively high launching power, the difference of EOP between channel 1 and 16 is so very large that is impossible to find out optimal parameter values, this feature is quite unlike Fig. 6. For this reason, the launching powers are assumed to be 0 dBm in this paper. It is shown from Fig. 6 that the optimal OPC position, which result in the smallest EOP difference between channel 1 and 16, is 496 km($\Delta z=-4$ km) in both cases of $\Delta D_{1,x}=2$ and 4 ps/nm/km. In Fig. 6, the symmetry of EOP differences with respect to $\Delta z=-4$ km is appeared. This feature means that this OPC position will make the power and local dispersion into symmetrical distribution, if the optimal dispersion offset will be obtained to 0 ps/nm/km at this position.

Fig. 7 shows EOP difference between channel 1 and 16 depending on the dispersion offset, $\Delta D_{1,x}$ when the OPC placed at the position obtained from the results of Fig. 6. It is shown from Fig. 7 that the characteristics of EOP differences depending on ΔD_{11} and ΔD_{12} are nearly coincide with each other in all cases. And, it is confirmed that the best $\Delta D_{1,x}$, which result in the smallest EOP difference, are obtained to be 0 ps/nm/km in all cases. These facts mean that, in the case of fixing the dispersion coefficient of one fiber section, the dispersion offset of another fiber section will similarly affects the compensation extents each other, also mean that the best compensation for overall channels is obtained only by equalizing dispersion coefficients of both fiber sections each other in both cases of $D_{1,x}$, if OPC was placed at 496 km.

But, in the case of $D_{1,x} = 2$ ps/nm/km, EOP differences are gradually decreased as the values of $\Delta D_{1,x}$ are gradually increased in $|\Delta D_{1,x}| > 0.7$ ps/nm/km. These results mean that the best dispersion offset of fiber sections should be the value upper than ± 1.0 ps/nm/km. But, EOP of each channels are larger than 10 dB in this dispersion offset range. So it is meaningless to find out the optimal dispersion offset in this range.

Fig. 8 shows EOP of overall channels as a function of the launching light power in WDM system with the optimal OPC position and the optimal dispersion coefficients of fiber sections determined from the results of Fig. 6 and Fig. 7. The compensation extents shown in

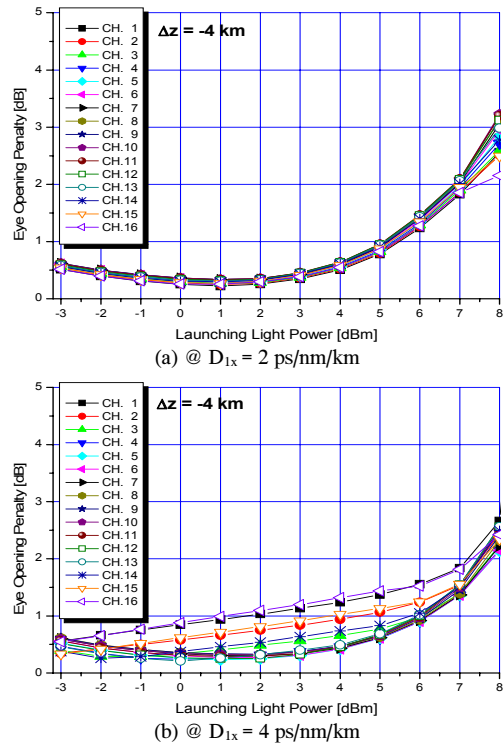

Fig. 8. EOP as a function of the launched light power in WDM system with the optimal parameters obtained from the result in Fig. 7.

Fig. 8 are largely improved than the results of Fig. 5. That is, if 1 dB EOP is allowed for performance criterion, it is confirmed that power penalty is reduced to 0.5 dB and 5.5 dB from 3 dB and 13 dB in the case of $D_{1,x}=2$ and 4 ps/nm/km, respectively. This fact means that compensation extents of overall channels are improved by applying optimal parameters into WDM system with OPC when the condition of the optical power and local dispersion symmetrical distribution were not made.

Up to now, the optimal OPC position is previously induced, and then the optimal dispersion coefficients depending on this optimal OPC position are consequently induced. It is required to exchange the procedure of finding out the optimal parameters for investigating the correlation of two optimal parameters.

Fig. 9 and 10 show the results obtained through the same numerical methods with the previous, but the reverse procedure of searching the optimal parameter. It is shown from Fig. 9 that EOP differences depending on ΔD_{11} under the condition of $\Delta D_{12} = 0$ ps/nm/km is sym-

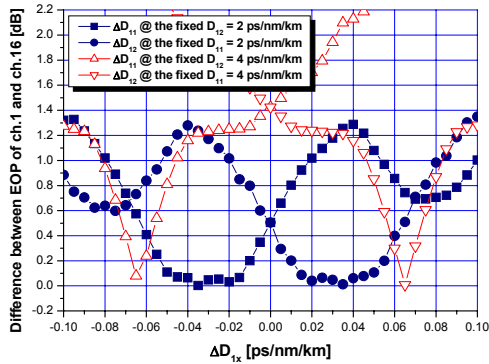

Fig. 9. EOP differences as a function of ΔD_{1x} in the case of assuming $\Delta z = 0$ km.

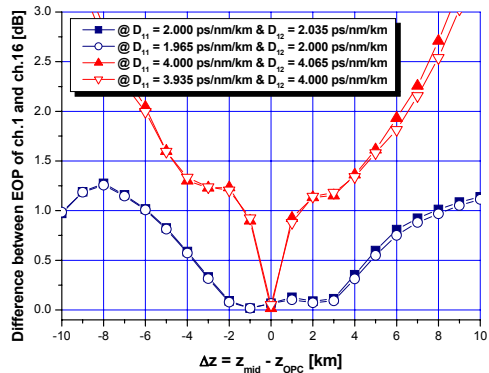

Fig. 10. EOP differences as a function of Δz for ΔD_{1x} .

metry with EOP differences depending on ΔD_{12} under the condition of $\Delta D_{11} = 0$ ps/nm/km. For example, the best ΔD_{11} that result in the smallest EOP difference is obtained to -0.035 ps/nm/km in the case of assuming $\Delta D_{12} = 0$ ps/nm/km, while the best ΔD_{12} is $+0.035$ ps/nm/km in the case of assuming $\Delta D_{11} = 0$ ps/nm/km for $D_{1x} = 2$ ps/nm/km. This means that the optimal difference value of dispersion coefficient between the two fiber sections must become 0.035 ps/nm/km, and the optimal dispersion coefficient of second fiber section must be larger as much as that than dispersion coefficient of first fiber section. Also, the optimal difference value of dispersion coefficient between two fiber sections are determined to 0.065 ps/nm/km in the cases of $D_{1x} = 4$ ps/nm/km.

It is shown from Fig. 10 that EOP differences between channel 1 and 16 in all cases of optimizing dispersion coefficients of first fiber section to $D_{11} = D_{1x} + \Delta D_{11}$ as the results of Fig. 9 under the assumption of $D_{12} = D_{1x}$ are nearly coincide with those in all cases of optimizing dis-

persion coefficients of second fiber section to $D_{12} = D_{1x} + \Delta D_{12}$ under the assumption of $D_{11} = D_{1x}$. For $D_{1x} = 2$ ps/nm/km in Fig. 10, the optimal Δz are all obtained to be -1 km in both cases. But, the optimal Δz are obtained to be 0 km for $D_{1x} = 4$ ps/nm/km.

Fig. 11 shows EOP of overall channels as a function of the launching light power in WDM system with the optimal OPC position and the optimal dispersion coefficients of fibers determined from the results of Fig. 10. Fig. 11 is comparing EOP characteristics obtained in the case of optimizing dispersion coefficients of second fiber section to $D_{12} = D_{1x} + \Delta D_{12}$ under the assumption of $D_{11} = D_{1x}$ (the left side figures of Fig. 11) with EOP characteristics obtained in the case of optimizing dispersion coefficients of first fiber section to $D_{11} = D_{1x} + \Delta D_{11}$ under the assumption of $D_{12} = D_{1x}$ (the right side figures of Fig. 11). It is shown that each EOP characteristics of the left side figures are similar with the right side figures.

By comparing Fig. 8 and 11, it is confirmed that the values of the optimal parameters are changed with the procedure of searching the optimal parameters, but the compensation extents of both cases are almost coincide with each other. That is, the values of the optimal parameters related with the finding procedure are not important, only if two optimal parameters depend on each other.

In the case of deciding the optimal dispersion coefficients after deciding the optimal OPC position, the optimal Δz are determined to -4 km and the optimal D_{1x} are determined to 0 ps/nm/km, and these values are irrelevant with fiber dispersion coefficients. On the other hand, in the case of deciding the optimal OPC position after deciding the optimal dispersion coefficients, the optimal values of Δz and D_{1x} are related with fiber dispersion coefficient. Thus the procedure that previously deciding the optimal OPC position and then deciding the optimal dispersion coefficients is more efficient than the reverse procedure.

It is confirmed by investigating the results of Fig. 8 and 11 that the optimal dispersion coefficient of the second fiber section is increased by 0.01167 ps/nm/km in the case of fixing only ΔD_{11} to 2 ps/nm/km or the optimal dispersion coefficient of the first fiber section is decreased by same amount in the case of fixing only ΔD_{12}

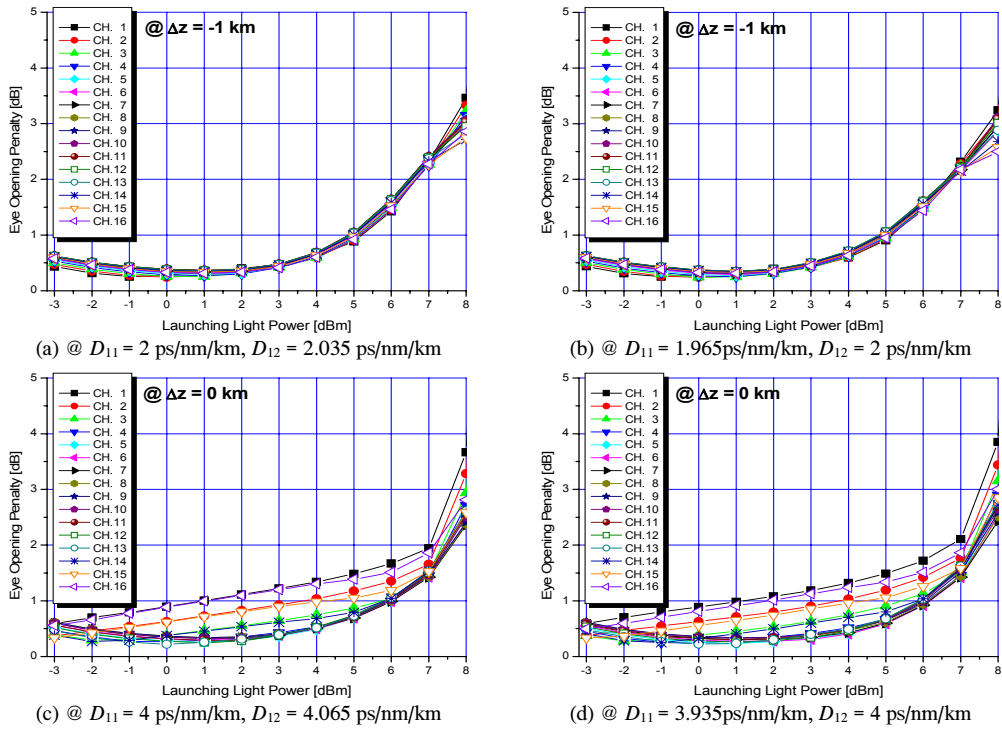

Fig. 11. EOPas a function of the launched light power in WDM system with the optimal parameters obtained from the results in Fig. 10.

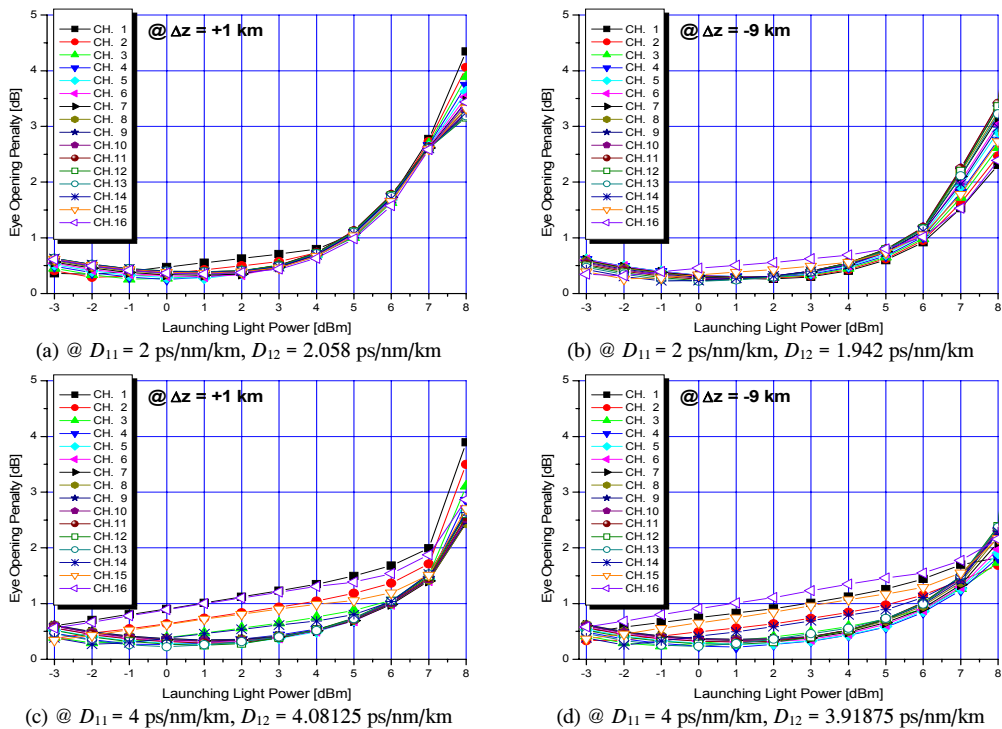

Fig. 12. EOPas a function of the launched light power in WDM system with the flexibly selected parameters.

to 2 ps/nm/km as the OPC position is closer to the receiver by 1 km, because the optimal ΔD_{12} is 0 ps/nm/km when the optimal OPC position is 496 km and the optimal ΔD_{12} is +0.035 ps/nm/km (or $\Delta D_{11} = -0.035$ ps/nm/km) when the optimal OPC position is 499 km. Of course, the optimal dispersion of the second fiber section is decreased by 0.01167 ps/nm/km in the case of fixing only ΔD_{11} to 2 ps/nm/km as the OPC position is reversely closer to the transmitter by 1 km. From the similar reason, that the optimal dispersions of the second fiber section is increased by 0.01625 ps/nm/km in the case of fixing only ΔD_{11} to 4 ps/nm/km as the OPC position is closer to the receiver by 1 km.

These facts will provide the flexibility in the case of designing WDM transmission system. That is, the OPC position or dispersion coefficient of fiber sections will be flexibly used in the design of WDM transmission system, for example, the optimal dispersion coefficient of second fiber section must be selected to 2.058 ($\doteq 2(=D_{1z})+0.01167 \times 5\text{km}$) ps/nm/km or 1.942 ($\doteq 2(=D_{1z})+0.01167 \times (-5\text{km})$) ps/nm/km when OPC is placed at 501 km or 491 km of 1,000 km NZ-DSF, respectively, when dispersion coefficient of first fiber section was fixed to 2 ps/nm/km.

Fig. 12 shows EOP of overall channels as a function of the launching light power in WDM system with the parameters previously mentioned. The results shown in Fig. 12 are nearly coincided with the results obtained from Fig. 8 and 11. Thus the optimal parameters induced in this research are expected to contribute to realizing the flexible WDM system in the case of using OPC for effectively compensating overall channels.

IV. Conclusion

Up to now, this paper deal with the finding method of the optimal OPC position and the optimal dispersion coefficients of fibers that are efficiently compensating for the distortion of 16 WDM channels of 40 Gbps and the investigating of performance improvement when these parameters applied into 16×40 Gbps WDM system, without the making of the symmetrical distribution of power and local dispersion in the case of using OPC.

First, it was confirmed that the numerical method considered in this research will be available to multi-channel

WDM system, irrelevant with the finding procedure of these two optimal parameters only if two optimal parameters depend on each other. And, it was confirmed that the results induced in this research will provide the improvement of the received signal and the flexibility of WDM transmission system design. Thus the applying of the optimal parameters induced in this proposed method into multi-channels WDM system with OPC will be expected to replace with the method for making the symmetrical distribution of power and local dispersion.

But, the optimal values of these parameters should be changed when XPM affects WDM signals. Therefore, the effect of chromatic dispersion and nonlinearities including XPM on the optimal values of parameters will be investigated in future research.

References

- [1] A. R. Chraplyvy, "Limitations on lightwave communications imposed by optical-fiber nonlinearities", *J. Lightwave Technol.*, Vol. 8, No. 10, pp. 1548~1557, 1990.
- [2] ITU Recommendation "Characteristics of a non-zero dispersion shifted single-mode optical fibre cable" G.655, 2003.
- [3] N. Shibata, K. Nosu, K. Iwashita and Y. Azuma, "Transmission limitations due to fiber nonlinearities in optical FDM systems", *IEEE J Select. Areas in Comm.*, Vol. 8, No. 6, pp. 1068~1077, 1990.
- [4] C. Lorattanasane and K. Kikuchi, "Design of long-distance optical transmission systems using midway optical phase conjugation", *IEEE Photon. Technol. Lett.*, Vol. 7, No. 11, pp 1375~1377, 1995.
- [5] S. Watanabe and M. Shirasaki, "Exact compensation for both chromatic dispersion and Kerr effect in a transmission fiber using optical phase conjugation", *J. Lightwave Technol.*, Vol. LT-14, No. 3, pp. 243~248, 1996.
- [6] S. Watanabe, S. Takeda, G. Ishikawa, H. Ooi, J. G. Nielsen and C. Sonne, "Simultaneous wavelength conversion and optical phase conjugation of 200 Gb/s (5×40 Gb/s) WDM Signal using a highly nonlinear fiber four-wave mixing", *ECOC 97 Conf.*, pp. 1~4, 1997.

- [7] G. P. Agrawal, *Nonlinear Fiber Optics*, Academic Press, 2001.
- [8] M. Wu and W. I. way, "Fiber nonlinearity limitations in ultra-dense WDM systems", *J. Lightwave Technol.*, Vol. 22, No. 6, pp. 1483~1498, 2004.
- [9] G. P. Agrawal, *Fiber-optic communication systems*, John Wiley & Sons, Inc., 2002.
- [10] K. Inoue, "Four-wave mixing in an optical fiber in the zero-dispersion wavelength region", *J. Lightwave Technol.*, Vol. LT-10, No. 11, pp. 1553~1561, 1992.
- [11] ITU Recommendation "Spectral grids for WDM applications : DWDM frequency grid" G.694.1, 2006.

Seong-Real Lee

Regular Member



He received the B.S., M.S. and Ph. D. degree in telecommunication and information eng. from Hankuk Aviation University, Korea in 1990, 1992 and 2002, respectively. He was a senior engineer at R&D center of Seyoung Co., Ltd. from January 1996 to June 2002, and CTO at R&D center of ATN Co., Ltd. from June 2002 to February 2004. He is currently an assistant professor at the Division of Marine Electronic and Communication Eng., Mokpo National Maritime University. His research interest include optical WDM systems, optical soliton systems and the optical non-linear effects.