

Network Scalability를 위한 네트워크 설계 및 최적화 방법에 관한 연구

정회원 이 동 선*

A Study on Network Planning and Optimization Strategy for Network Scalability

Dong Sun Lee* *Regular Member*

요 약

현재의 전송네트워크용량을 향상시킬때 중요하게 고려해야 할것중의 하나가 네트워크 scalability 이다. 새로운 풀 메쉬의 링 확장 방법 및 플래닝 툴을 제안하였다. 3~15 노드의 확장링에서 본 툴을 사용하여 SNR이 증진되는 것을 입증하였다. 노드의 출력신호 및 광 SNR이 제안된 NPOT에 의해 -16dBm/10dB 에서 +005dBm/21dB 로 증진되었다.

Key Words : WDM, SHR, EDFA, SNR, MUX

ABSTRACT

One of the major issues that has to be carefully considered when upgrading current transport network capacity, is network scalability. A novel full-meshed connected ring expansion methodology and planning tool have been proposed. A 3 to 15 node expansion ring has been studied by demonstrating a dramatic system SNR improvement when the proposed planning tool was used. The results are that node output signal and optical SNR have been improved from -16dBm/10dB to +005dBm/21dB by NPOT.

I. Introduction

Aggregate bandwidth required by the internet is expected to be explosively increased. To meet this anticipated need, a survivable, and scalable ultra-high speed core transport network capable of supporting for an aggregate network capacity in the order of a Tbps is required. One of the major issues that has to be carefully considered, when upgrading current transport network capacity is network scalability. Network scalability refers to how can one scale up the size and capacity of the

network, to accommodate gradual/sudden increase in traffic demand without affecting/changing the existing networking infrastructure. To ensure that the network is scalable, a network planning and optimization strategy, at the initial phase of the system design, that allows a smooth network evolution while maintaining adequate end-to-end performance, independent of the network size, for all wavelength signals across the network will be developed in this paper. A ring topology is selected as a candidate to investigate the scalability and survivability issues of core transport network.

* 광운대학교 정보제어공학과 (dsleekorea@hanmail.net)

논문번호 : KICS2004-07-120, 접수일자 : 2004년 7월 28일, 최종논문접수일자 : 2007년 6월 13일

II. Overview of Self-Healing Ring Network

A bi-directional WDM(Wavelength-Division Multiplexing) SHR(Self-Healing Ring) architecture is appropriate for connecting a set of broadband switches full mesh traffic pattern. The block diagram of the network under a line failure between node 1 and node 2 is shown in Figure 1. The optical switches at both sides of the link are reconfigured in a way that allows the traffic from node 1 to node 2 go through node 5, node 4, node 3 and finally node 2 on the protection path. The block diagram of protection state of equipment failure inside the optical node is shown in Figure 1. In this case, all optical switches at both sides of the node are reconfigured to allow continuous communications between the all other nodes and isolate failure node. The protection switching decision is made at optical layer. Therefore, the SONET ADMs can be much simpler than the conventional BLSR.

The advantages of using all-optical protection are that: (1) the network can achieve the transparency at bit rate and format, (2) the network architecture will be simpler. But the optical protection can protect only facility failure.

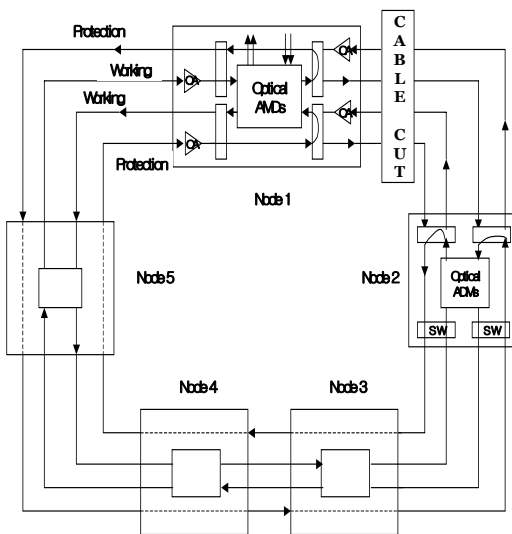

Fig. 1. The block diagram of protection state at fiber cut between Node 1 and 2

III. Optimal Wavelength Planning and Performance Analysis for Scaling DWDM-Based Core Transport Network

3.1. DWDM-Based Core Transport Network Evolution

While WDM is expected to dominate the backbone, its role in an access environment is just beginning to take shape, with vendors starting to discuss WDM access network solutions, particularly to serve business customer. Huge bandwidth is one advantage of deploying WDM in an access environment; however, the main advantages lie in the enhanced flexibility and upgradability that WDM provides.

Because of the proximity of the end-users, an access network is quite different from a long distance backbone network. A backbone network carries traffic that, for the most part, has already been multiplexed and groomed, and hence has less variability. On the other hand, the traffic characteristic of an access network is highly variable subject to the ever increasingly customer demand. An access network must accommodate a wide range of data formats and data rates. In addition, it must also be scalable in terms of both number of customers and traffic demands of any given customer. Thus, an access network needs to be more flexible and scalable. WDM ring network is capable of providing restoration capabilities and can be a powerful candidate for both backbone and access network application. Figure 2 shows a high-level view of an access network architecture that is functionally partitioned into the multiple distribution networks and the feeder network[1]. End users are locally connected to the distribution networks, which in turn connected to the access nodes in the feeder network. In addition to connecting access/egress nodes to one another, the feeder network also has one or more connections to the communication backbone via the egress nodes. The feeder network has a ring topology on which are located a set of access nodes and egress nodes. Feeder access nodes can be interconnected by multiple fibers for greater

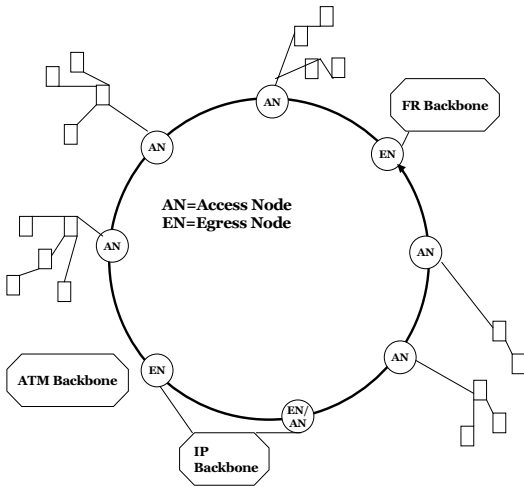

Fig. 2. The high-end access network architecture

capacity and route diversity. This paper uses 4-fiber bi-directional WDM ring network feeder configuration for its simplicity while providing powerful protection function in case of fiber cuts.

As the number of end-users increase, and as their usage patterns evolve to include more bandwidth-intensive internet applications, there emerges an acute need to scale up the number of the nodes of the feeder ring network while satisfying the following two critical requirements:

Req't A. The wavelength assignment plan should provide a full-mesh traffic pattern among all nodes while allowing a graceful network evolution scenario from a standard single wavelength small SONET(3 nodes) ring a multiwavelength full-mesh connected large ring with N nodes($N > 3$) with the following criterion: the addition of every new node will not change the wavelength assignment for the nodes already in the network.

Req't B. Maintaining adequate end-to-end performance for all wavelength signals across the ring should be independent of the network size and/or the total span length traversed by a given signal wavelength. As the network size scales up, a given signal wavelength would now traverse more nodes en route to its final destination in order to keep the same connectivity. Signal degradation can occur at each node due to finite

filter passband and filter misalignment, added crosstalk signals, added EDFA ASE noise, and wavelength dependent gain.

Therefore, a network planning and optimization strategy that allows a smooth network evolution while maintaining adequate end-to-end performance, independent of the network size, for all wavelength signals across the ring is needed at the initial phase of the system design. It is shown here that satisfying only the first requirement may not be sufficient to achieve adequate end-to-end performance for all wavelength signals across the ring.

The next section presents a scalability performance analysis of a full-mesh WDM ring network when operated in an access environment. Specifically, this paper proposes a novel and simple NPOT(Networking Planning and Optimization Tool) that interrelate the networking layer wavelength assignment algorithm with the physical layer transmission impairments for best overall full-meshed connected WDM ring performance when operated in an access environment.

3.2. Network Planning and Optimization Tool(NPOT)

A 4-fiber bi-directional WDM ring topology is considered as the feeder network for an access environment. It starts up with 3 nodes and then scales up this number up to 15 nodes(2 nodes are assumed to be added at each stage). Figure 3 shows one of the extreme cases of the network evolution from 3 nodes single wavelength ring up to 15 nodes 28 wavelengths mesh connected ring(the number of the node indicates the sequence of the node being added on). The entire sequence of adding the nodes is shown in Figure 3, and a connectivity and wavelength assignment algorithm for the network evolution is determined(according to the above first requirement) based on the following described approach.

A matrix approach has been found to work best for wavelength assignment algorithm for 4-fiber SHR. By appropriately filling in the matrix, while following some simple rules, all the

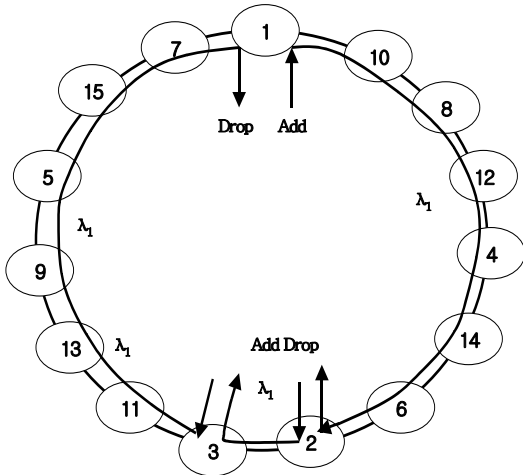
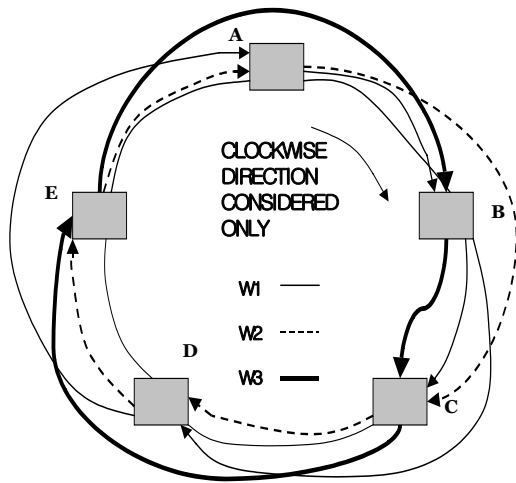

Fig. 3. The worst possible scenario for ring network evolution

W\TH	A	B	C	D	E
W1	1	2	X	2	X
W2	2	X	1	1	1
W3	X	1	2	X	2

(a)



(b)

Fig. 4. Wavelength assignment
 (a) Wavelength assignment matrix for N=5 nodes on the ring (b) Wavelength assignment for N=5 nodes on the ring

wavelength assignment can be got. Figure 4(a) shows an example of a matrix for a ring network with N=5 nodes(3 wavelengths required). The value placed in the matrix represent half of the

connections(clockwise direction only) from each node to every other node on the ring. A value K in position(i, j) states that node j is connected to node(j+K) mod(N) using wavelength i. Figure 4(b) shows the full mesh connectivity for this ring and the wavelength assignment obtained from the matrix for the clockwise direction connections. The identical assignment is valid for the rest of connections in the counter-clockwise direction.

The general rules for the wavelength assignment algorithm are:

A. K is the number of node for one wavelength cross over including the originating node. The maximum number is(N-1)/2.

B. In a row(wavelength), wherever put the number K in the matrix, one must leave K-1 spaces blocked not available for any number. If one dose not block these spaces on that row, someone else uses the same wavelength on the same segments which cause two paths intersect.

C. In a column, one can not have two K values the same. Otherwise one would have duplicated path using different wavelength.

D. Summation of all the values in a row must equal to N. This is true because one wavelength has to go over the close the ring exactly once.

E. When follow the rules above, the summation of one column should equal to total number of wavelength.

Network evolution requires scaling the existing network by adding a single node at a time, without disrupting already existing connections, this matrix filling method is extended to satisfy this requirement according to the different characteristics of scaling rings with even and odd number of nodes.

Case 1 : The network extends from even number of node ($N_{new} = N_{odd}+1$)

The matrix size for existing ring network is $W \times N$ ($W = \frac{N^2-1}{8}$) to $W' \times N_{new}$, here $W' = \frac{(N_{new})^2}{8}$ Or $W' = \frac{(N_{new})^2+4}{8}$. The new

column can be added at any position in the matrix. For each row, from the new column, the algorithm traverses the row towards the left until it encounters the first entry(other than X). The first W rows of the new column are then filled following rules 1 and 2 below. The rest the rows are filled with the longest connection entries.

Rule 1 : If the entry encountered K, is not an entry of a longest connection Lmax, ($L_{max} = \left\lfloor \frac{N_{odd}}{2} \right\rfloor$), place an X at the new column and increment K by 1.

Rule 2 : If the entry encountered K, equals to Lmax, the algorithm places the number M=Q+1 at new column and entry K becomes K'=(K-Q). The number of A denotes the number of X's that follow the new column for the specific row.

Case 2 : The network extends from odd number of node ($N_{new} = N_{even} + 1$)

The matrix is expanded from WXN_{even} To $W' \times N_{new}$ ($W' = \frac{(N_{new})^2 - 1}{8}$). For the new column, for rows 1, ..., ($\frac{(N_{even} - 1)^2 - 1}{8}$), the algorithm follows Rule 1. For rows ($\frac{(N_{even} - 1)^2 - 1}{8} + 1$, ..., W(where W equals to the number of wavelengths for N_{even} ($W = \frac{N_{even}^2}{8}$) If N_{even} is divisible by 2 and 4 or $W = \frac{N_{even}^2 + 4}{8}$ If N_{even} is divisible by 2 but not by 4, the algorithm follows Rule 2. For rows (W+1), ..., W', the algorithm places in the new column the connection entries that are not used in the rows above for that column. The rest of the row entries are filled appropriately. Table 1 shows the RWA(Routing And Wavelength Assignment) for 15 nodes on the ring, which evolves from 3 nodes ring.

Note how the addition of new nodes might increase the initial number of spans traversed by a given wavelength channel and consequently

Table 1. The routing and wavelength assignment For 15 nodes ring (the first column is the order of wavelengths, the first Row is the re-ordered node locations which correspond to the real positions In the ring, such as the node 9 in re-ordered ring is the node 2 in Figure 2-7)

W\TH	1	2	3	4	5	6	7	8	9	10	11	12	13	14	15
W1	7	x	x	x	x	x	x	1	7	x	x	x	x	x	x
W2	x	x	6	x	x	x	x	1	1	1	2	x	4	x	x
W3	4	x	x	5	x	x	x	2	x	1	1	2	x	x	x
W4	6	x	x	x	x	2	x	2	x	2	x	3	x	x	x
W5	2	x	4	x	x	4	x	x	x	3	x	x	1	1	1
W6	x	x	x	4	x	x	x	3	x	x	3	x	x	5	5
W7	x	x	7	x	x	x	x	x	3	x	x	2	x	3	3
W8	1	1	2	x	7	x	x	x	x	x	4	x	x	x	x
W9	x	7	x	x	x	x	x	4	x	x	x	4	x	x	x
W10	x	5	x	x	x	3	x	x	4	x	x	x	3	x	x
W11	x	3	x	x	6	x	x	x	x	4	x	x	x	2	2
W12	x	x	1	1	2	x	6	x	x	x	x	5	x	x	x
W13	x	x	x	5	x	x	x	5	x	x	x	x	5	x	x
W14	x	x	x	6	x	x	x	x	5	x	x	x	x	4	4
W15	3	x	x	7	x	x	x	x	x	5	x	x	x	x	x
W16	x	2	x	3	x	x	5	x	x	x	5	x	x	x	x
W17	x	x	x	1	1	7	x	x	x	x	x	6	x	x	x
W18	x	x	x	x	3	x	x	6	x	x	x	x	x	6	6
W19	5	x	x	x	4	x	x	x	6	x	x	x	x	x	x
W20	x	4	x	x	5	x	x	x	6	x	x	x	x	x	x
W21	x	x	3	x	x	6	x	x	x	x	6	x	x	x	x
W22	x	x	x	2	x	7	x	x	x	x	x	6	x	x	x
W23	x	x	x	x	x	1	7	x	x	x	x	x	x	7	7
W24	x	6	x	x	x	x	2	x	7	x	x	x	x	x	x
W25	x	x	5	x	x	x	3	x	x	7	x	x	x	x	x
W26	x	x	x	4	x	x	x	4	x	x	7	x	x	x	x
W27	x	x	x	x	3	x	x	5	x	x	x	7	x	x	x
W28	x	x	x	x	x	2	x	6	x	x	x	x	x	7	x

degrade its end-to-end performance. For example, the worst case scenario longest path channel λ_1 , shown in Figure 3, which initially links only the adjacent nodes at the initial deployment of a 3 nodes ring(traverses a maximum of only one span), will eventually cross over 7 nodes(traverses a maximum of spans) to maintain the same connectivity when the ring size has evolved from 3 nodes up to 15 nodes.

Assume that wavelengths are arbitrarily assigned to the ring nodes and that the obvious channel-wavelength allocation $[(\lambda_1, \lambda_2, \dots, \lambda_{28})=(1538, \dots, 1559.8)\text{nm}]$ is used, where the 1538.2~ 1559.8nm spectral region is the amplifier band assigned to the signals wavelength. In this case, the longest path channel λ_1 is assigned the 1539.2nm signal wavelength. However, the physical characteristics of the EDFAs used here is such that the 1538.2nm signal wavelength has the lowest intrinsic amplifier gain(and consequently the lowest SNR) from among all the 28 signal wavelengths. This would further degrade the end-to-end performance of the longest path

channel λ_1 , with the result that its output SNR, as will be shown, may not be adequate for multi Gbps operation. Thus, signal wavelength with the highest SNR from among all of the 28-wavelength signals may thus be assigned to the longest path channel λ_1 in order to maintain an adequate end-to-end channel performance. Using the same reasoning, signal wavelength with the lowest SNR from among all of the 28-wavelength signals may be assigned to the shortest path channel.

What is needed is an intelligent NPOT that interrelates the networking layer wavelength assignment algorithm with the physical layer transmission impairments for best overall system performance. The NPOT works as follows:

Step 1 : Develop a wavelength assignment matrix that satisfy Req't 1, from which locate those wavelengths with the longest possible total span length around the ring and its corresponding number of cascaded EDFAs.

Step 2 : Optimize the performance of the EDFAs to be used across the ring, in terms of maximum gain, flatness, and lowest noise figure, for the total number of wavelengths(including those that are expected to be used in the future and won't be in service at the initial deployment) over the number of cascaded EDFAs determined in step 1.

Step 3 : Observe the SNR evolution of the dropping wavelengths at different expansion stage of the ring in each node.

Step 4 : Optimize the wavelength assignment algorithm(determined in step 1) by reassigning wavelength signals with the highest SNR for the longest path channels and those with the lowest SNR for the shortest path channels.

3.3. Node Architecture

Figure 5 shows a block diagram of an optical node. The WDM signal coming from working path will pass optical switch first followed by wavelength demultiplexer. Some of the wavelengths will be dropped at the node and

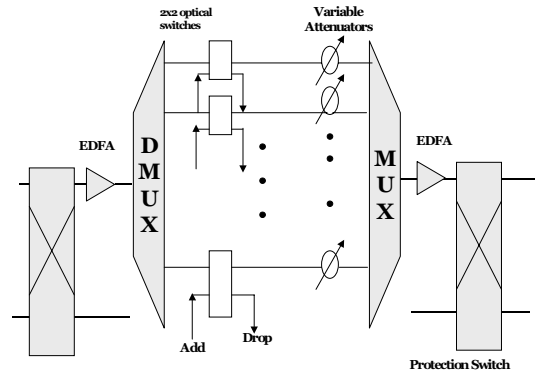

Fig. 5. The node architecture for working ring

some of them just pass through it. The wavelengths dropped will be terminated at each SONET BLSR ADM. The number of SONET ADM is equal to number of wavelength dropped in this node. The outgoing signals will pass the following optical switches before leaving the node.

The system model consists of $28\lambda-10$ Gbps WDM channels spaced 100 GHz apart in the 1538.2 to 1559.8nm amplifier band. The preamplifier is used to compensate the loss that is caused by DMUX/MUX, and optical switches. The poster-amplifier compensates the span loss during transmission. The amplifier is the critical component, it should has low-noise and high gain. In order to get flatted gain spectrum, gain equalization technologies are used.

In our system model, each amplifier in the network is a 2stage EDFA, optimized at 15m 1st stage and 40m 2nd stage, with an isolator in between. Each single stage amplifier is co-directionally pumped with 90 mW of pump power at 980nm. The input signal levels are -18 dBm/channel at the input of the first amplifier. Variable optical attenuators are used for gain equalization. The signals at each node are dropped/added using commercially available DMUX/MUX filters. Each node drops seven wavelengths and adds seven new signals(same wavelengths) at -18 dBm/channel, according to the dropping plan. The average dual-stage EDFA gain = 22 dB compensates for the total system loss including MUX/DMUX insertion loss, Variable

optical attenuators loss, optical switches loss, and a fiber span loss of 10 dB, which allows about 40 km separation between successive nodes.

The signal and ASE power accumulation along the EDFA chain is determined based on the spectrally resolved numerical model. The accumulated optical SNR reported here is the ratio between the signal level and the accumulated ASE noise power in a 0.2nm optical bandwidth. The end-to-end system performance is estimated from the optical SNR, which must be more than 18 dB to achieve a bit-error rate(BER) of 10^{-14} at 10 Gbps.

IV. Simulation Results

Figure 6 shows the output signal levels and noise spectra at node 3 for two cases:

Case 1: Wavelengths are arbitrarily assigned to the ring nodes and the obvious channel-wavelength allocation $[(\lambda_1, \lambda_2, \dots, \lambda_{28}) = (1538.2, 1540, \dots, 1559.8)\text{nm}]$ is used. In this case, the longest path channel λ_1 is assigned the first wavelength slot (1538.2nm).

Case 2: The NPOT is used to reassign the channel-wavelength allocation as follows: $[(\lambda_1, \lambda_2, \dots, \lambda_{28}) = (1551, 1540, \dots, 1559.8) \text{ nm}]$. Note how the NPOT reassigns the longest path channel λ_1 to wavelength slot # 16(1551nm). The 1551nm signal wavelength has both the highest amplifier gain and SNR, and still maintains the highest gain and SNR after emerging from 14 cascaded EDFAs. Note also that Wavelength slot # 1(1538.2nm) has been reassigned to the shortest path channel (channel # 28) which just connects two adjacent nodes.

Node 3 is chosen because in the example presented here, it represents the worst case scenario due to: 1) it contains the optical signal at the shortest wavelength(1538.2nm), corresponding to the lowest amplifier gain; 2) Node 3 drops the signal after it has traversed the longest cascade of amplifiers(14 EDFAs), being added at node 1 and traversing 7 nodes before dropping at node 3. As can be seen from Figure 6, in case 1, at $\lambda_1 =$

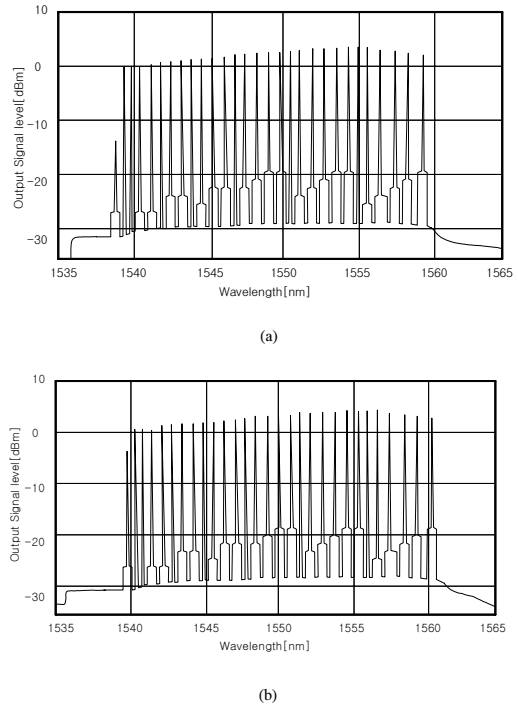

Figure 6. Signal spectra (a) without NPOT (b) with NPOT

1538.2nm, both the output signal level(-16 dBm) and the optical SNR(10 dB) are insufficient for 10 Gbps operation. However, in case2, at $\lambda_1 = 1551\text{nm}$, both the output signal(0 dBm) and the optical SNR(21 dB) are sufficient for 10 Gbps operation.

V. Conclusion

A novel full-meshed connected ring expansion methodology and planning tool have been proposed. The planning tool relates the physical layer wavelength characteristics with network layer wavelength assignment to get the best system performance. A 3 to 15 expansion ring has been studied by demonstrating a dramatic system SNR improvement when the proposed planning tool was used. The results are that node output signal and optical SNR have been improved from -16dBm/10dB to +005dBm/21dB by NPOT in case of severely degraded channel. This study has suggested that the network operator need to consider the long-term expansion plan before

selecting the first set of wavelengths for the access full-mesh ring.

References

[1] Jane M Simmous and Adel Saleh, "Optical Regional Access Network(Oran) Project", OFC '99, Paper WK1-1, 1999.

[2] A. F. Elrefaie, "Multi-Wavelength Survivable Ring Network Architectures", ICC '93, Paper48. pp.23-26, May 1993.

[3] Cutis A. Siller, Mansoor Shafi, "Synchronous Optical Network Digital Hierarchy: an Overview of Synchronous Networking", IEEE Press, pp.11-15, 1996.

[4] A. F. Elrefaie, "Self-Healing WDM Ring Network Architecture with All-Optical Protection Path", OFC '92, Tech. Digest, Vol. 5, pp.255-256, 1992.

[5] Erland Almstrom, Charles Hubinette and Sonny Johansson, "A Uni-Directional Self-Healing Ring using WDM Technique", 5Th OEC '94, Tech. Digest, Paper 13C1-4, Product Brochure, Dicon Fiberoptics, Inc, 1994.

[6] C. R. Giles and E. Desurvire, "Modeling Erbium-Doped Fiber Amplifiers", J. Lightwave Technology, Vol. 9, pp.271-283, 1991.

[7] Dietrich Marcuse, "Derivation of Analytical Expressions for the Bit-Error Probability in Lightwave Systems with Optical Amplifiers", J. Lightwave Technology, Vol. 8, No, 12, pp.1816- 1823, 1990.

[8] Jane M Simmons and Adel Saleh, "Optical Regional Access Network (Oran) Project", OFC '99, Paper WK1-1, 1999.

[9] F. Elrefaie, "Multi-Wavelength Survivable Ring Network Architectures", ICC '93, Paper48, pp.23-26, May 1993.

[10] M.Rochette, "Gain Equalization of Edfas with Brag Gratings", IEEE Phostonics Technology Letters, May 1999.

[11] S. Artigaud, "Transmission of 16×10 Gbps Channels Spanning 24 Nm over 531Km of Conventional Single-Mode Fiber Using 7 In-Line Fluoride-Based EDFAs", Proc. Of OFC '96 Post- Deadline Paper PD27, San Jose, Cal., 1996.

[12] G. Meltz, W.W. Moery, And W.H. Glenn, "Formation of Bragg Gratings in Optical Fiber by a Transvers Holographic Method, "Opt. Lett., Vol. 14, pp.823-825, 1998.

[13] G. Ellinas, K. Bala, G.K. Chang, "Scalability of a Novel Wavelength Assignment Algorithm for WDM Shared Protection Rings", OFC'98 Technical Digest. 1998.

[14] J. J. Pan., "0.4nm Channel Spacing Dense WDM Multiplexer And Demultiplexer using FBGs and Bandpass Filters", OFC'98 Technical Digest.,1998.

이 동 선 (Dong Sun Lee)

정희원

1984년 2월 광운대학교 공대 전기공학과(공학사)
1987년 8월 광운대학원 전기공학과(공학석사)
2004년 8월 광운대학원 정보 제어공학과(공학박사)
2004년 9월~현재 SNS네트웍스 / 대표이사
<관심분야> 광통신공학, WDM, 광무선신호