

평균전력과 첨두전력 제한이 있는 폐루프 송신 안테나 다이버시티 시스템에서의 최적 안테나 가중치 방식 연구

정회원 이 예 훈*

On the Optimal Antenna Weighting Method for Closed-Loop Transmit Antenna Diversity with Average and Peak Power Constraints

Ye Hoon Lee* *Regular Member*

요 약

본 논문에서는 레일리 페이딩 채널환경에서 폐루프 송신 안테나 다이버시티 시스템을 위한 최적의 안테나 가중치 방식을 연구한다. 평균전력 및 첨두 전력의 제한이 있는 경우에 폐루프 송신 안테나 다이버시티의 평균 비트 오류율을 최소화하는 최적의 송신 안테나 가중치를 닫힌 형식의 수학적식으로 유도한다. 본 논문의 결과로부터 첨두 전력의 제한으로 인한 평균 비트 오류율 성능의 열화는 사용가능한 평균전력이 커질수록 그리고/또는 송신 안테나 개수가 증가할수록 그 성능 열화의 정도가 더욱 커짐을 알 수 있다.

Key Words : Transmitter Weights, Transmit Antenna Diversity, Peak Transmit Power

ABSTRACT

We consider an optimal antenna weighting scheme for a closed-loop transmit antenna diversity system in Rayleigh fading channels. We derive a closed-form expression for the optimal transmitter weights that minimize the average bit error rate (BER) subject to fixed average and peak transmit power constraints. It is shown that the peak power limitation degrades the average BER performance more significantly as the available average power and/or the number of transmit antennas increase.

I. Introduction

The aim of transmit antenna diversity (TAD) is to improve the performance of wireless communications through the use of multiple transmit antennas^[1]. In^[2,4], the transmitter weights of the closed-loop TAD are adapted to maximize the received signal-to-noise ratio (SNR) (termed as "maximal ratio transmission (MRT)"^[2]), and the

transmit power is normalized so that the total amount of instantaneous power is not altered for each symbol transmission. The use of adaptive antenna array for power-controlled cellular CDMA systems is considered in^[5], and joint transmit power control and receive beamforming is investigated in^[6]. An iterative algorithm for joint transmit beamforming and power control in downlink cellular systems is proposed in^[7], and

* 서울산업대학교, 전자정보공학과 (y.lee@snut.ac.kr)

논문번호 : KICS2007-06-273, 접수일자 : 2007년 6월 13일, 최종논문접수일자 : 2007년 6월 25일

the computational complexity is improved in^[8,9]. Combining transmit beamforming with channel inversion power control¹ is comprehensively studied in^[12]. However, the channel inversion requires large amount of transmit power in order to compensate for deep fade, which makes it not feasible to keep constant SNR with practical power amplifiers having peak power limitation.

In this paper, unlike aforementioned references where the effect of limited peak power was not addressed, we consider a closed-loop TAD system with limited average and peak transmit power constraints. We present a closed-form expression for the optimal transmitter weights that minimizes the average bit error rate (BER) subject to the constraints. In fact, average BER is a typical performance measure, especially for voice communications, and is employed as a design constraint in adaptive modulation systems^[13]. Our results show that the peak power limitation has an effect on the average BER performance of the optimal weighting scheme more significantly as the average transmit power and/or the number of transmit antennas increase. In this work, we assume perfect channel state information (CSI) is provided at both the transmitter and the receiver. The impact of imperfect CSI can be accounted for by applying the previous results in^[12,14] (and references therein) to this paper.

This paper is organized as follows. In Section II, we introduce the system model and formulate

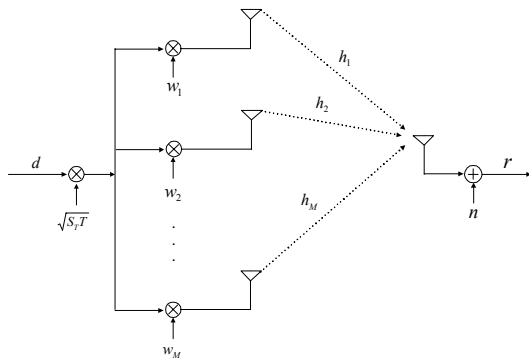

Fig. 1. System model

¹The channel inversion power control inverts the channel fading to maintain the received SNR at a fixed value^[10,11].

the average BER. In Section III, we analyze the optimal antenna weights that minimize the average BER under the constraints of fixed average and peak transmit power. Numerical results and discussions are presented in Section IV. Finally, conclusions are made in Section V.

II. System Model

For closed-loop TAD system, multiple copies of a data symbol are transmitted through multiple transmit antennas with different weights. The baseband equivalent system model of a closed-loop TAD to be considered in this paper is shown in Fig. 1. We assume that M transmit antennas are employed, and the channel is slowly time varying and frequency flat fading. To calculate each transmit antenna weight, the CSI is required. In this paper, we assume that perfect CSI is provided at the transmitter. The received signal at the receiver can be written as

$$r = \sqrt{S_T T} \left(\sum_{m=1}^M w_m h_m \right) d + n \quad (1)$$

where d is the binary data symbol with the probability $\Pr\{d=+1\} = \Pr\{d=-1\} = 1/2$, S_T is the average transmit power, T is the symbol duration, and n is the background zero-mean complex Gaussian noise of variance N_0 . h_m 's are the channel responses from the m th transmit antenna to the receiver, which are assumed to be independent and identically distributed zero-mean complex Gaussian random variables with $E[|h_m|^2]=1$. Finally, W_m is the transmitter weight for the m th transmit antenna. In order to satisfy a fixed average transmit power constraint,

$$E \left[\sum_{m=1}^M |w_m|^2 \right] = 1 \quad (2)$$

The instantaneous received SNR, γ , can be expressed as]

$$\gamma = \frac{S_T \left| \sum_{m=1}^M w_m h_m \right|^2}{N_0} \quad (3)$$

Then, the average BER, \bar{P}_b , is given by

$$\bar{P}_b = E_{h_1, h_2, \dots, h_M} [Q(\sqrt{2\gamma})] \quad (4)$$

where $Q(x)$ is defined as

$$Q(x) \equiv \frac{1}{\sqrt{2\pi}} \int_x^\infty e^{-t^2/2} dt, \quad x \geq 0 \quad (5)$$

III. Optimal TAD with Average and Peak Power Constraints

We first consider finding the optimal transmitter weights, W_m 's, that minimize the average BER (4) subject to the fixed average power constraint in (2), and then include additional peak power constraint later. We can formulate an optimization problem as follows:

$$\begin{aligned} \text{minimize } \bar{P}_b &= E_{h_1, h_2, \dots, h_M} [Q(\sqrt{2\gamma})] \\ \text{subject to : } & E \left[\sum_{m=1}^M |w_m|^2 \right] = 1 \end{aligned} \quad (6)$$

Note that the average power constraint in (6) can be split into

$$E \left[\sum_{m=1}^M |w_m|^2 \right] = 1 \Leftrightarrow \sum_{m=1}^M |w_m|^2 = P, \quad E[P] = 1 \quad (7)$$

where the *power allocation factor* P represents the amount of transmit power allocated in the time domain for each symbol transmission. From the *Cauchy-Schwartz inequality* [15, p. 441], the SNR γ in (3) for a given $\sum_{m=1}^M |W_m|^2 = P$ is upper bounded by

$$\gamma \leq \frac{S_T T \left(\sum_{m=1}^M |w_m|^2 \right) \left(\sum_{m=1}^M |h_m|^2 \right)}{N_o} = \frac{P S_T T \sum_{m=1}^M |h_m|^2}{N_o} \quad (8)$$

where the equality is satisfied when

$$w_m = c h_m^* \quad (9)$$

where the superscript $*$ denotes the complex conjugate and c is a real constant. It follows from the constraint $\sum_{m=1}^M |W_m|^2 = P$ that the constant c is given by

$$c = \sqrt{P / \sum_{m=1}^M |h_m|^2} \quad (10)$$

Hence, substituting (10) in (9) yields W_m as

$$w_m = \sqrt{P} h_m^* / \sqrt{\sum_{m=1}^M |h_m|^2}, \quad m = 1, 2, \dots, M \quad (11)$$

Since $Q(\sqrt{x})$ is a monotonically decreasing function of $x \geq 0$, this choice of W_m in (11), which maximizes the SNR given P , minimizes the instantaneous BER. Then, with (7) and (11), the minimization problem (6) can be reduced to

$$\begin{aligned} \text{minimize } \bar{P}_b &= \int_0^\infty Q \left(\sqrt{\frac{2PS_T T}{N_o}} \right) F_g(g) dg \quad \text{subject to :} \\ E[P] &= \int_0^\infty P F_g(g) dg = 1 \end{aligned} \quad (12)$$

where G is defined as

$$G \equiv \sum_{m=1}^M |h_m|^2 \quad (13)$$

and the pdf of G is chi-square distributed with $2M$ degrees of freedom^[16]

$$F_G(g) = \frac{g^{M-1} e^{-g}}{(M-1)!}, \quad g \geq 0 \quad (14)$$

The minimization problem (12) can be solved analytically using the *calculus of variations* and the method of *Lagrange multipliers*^[17]. Defining $I \equiv \bar{P}_b + \lambda(E[P] - 1)$, where λ is the Lagrange multiplier, and setting the derivative of I with respect to P equal to zero, we obtain the necessary condition for the optimal solution P :

$$\frac{\partial}{\partial P} \left[Q \left(\sqrt{\frac{2PS_T T}{N_o}} \right) + \lambda P \right] = 0 \quad (15)$$

By using the fact that $\frac{dQ(x)}{dx} = -\frac{1}{\sqrt{2\pi}} e^{-x^2/2}$ and

the chain rule, we get an implicit expression for the solution P as

$$P e^{2PGS_T T/N_0} = \frac{S_T TG}{4\pi\lambda^2 N_0} \quad (16)$$

The closed-form solution for (16) can be obtained as^[18]

$$P = \frac{W\left(\left(\frac{S_T TG}{\sqrt{2\pi}\lambda N_0}\right)^2\right)}{2GS_T T/N_0} \quad (17)$$

where $W(\cdot)$ is the Lambert W function^[19], which is defined to be the function satisfying

$$W(z)e^{W(z)} = z \quad (18)$$

For each symbol transmission, the optimal policy in (12) allocates the instantaneous transmit power PS_T in the time domain, but the maximum value of transmit power PS_T may be restricted due to the peak power limits in practical power amplifiers. Here, we assume that the transmit power PS_T for each symbol transmission is subject to a peak transmit power limit of S_{max} , or

$$P \leq S_{max}/S_T \quad (19)$$

Then, we now want to find an optimal power allocation actor P by solving the minimization problem (12) with the additional peak power constraint (19). In order to include the effect of imposing additional inequality peak power constraint, we should take two possibilities into account: (i) The optimal P is such that $P < S_{max}/S_T$, that is, the peak transmit power constraint is inactive. In this case, the optimal solution is still the same form as in (17). (ii) The optimal P is such that $P = S_{max}/S_T$, namely, the peak transmit power constraint is active^[17]. Considering both cases, the optimal power allocation factor P , with the additional peak transmit power constraints, is given as

²Obviously, the look-up table approach can be employed in practical hardware realization of the W function.

³In order to calculate the average BER performance with the MRT, see [4, eq. (5)].

$$P = \min\left(\frac{W\left(\left(\frac{S_T Tg}{\sqrt{2\pi}\lambda N_0}\right)^2\right)}{2gS_T T/N_0}, \frac{S_{max}}{S_T}\right) \quad (20)$$

The constant λ must satisfy the average power constraint

$$E[P] = \int_0^\infty \min\left(\frac{W\left(\left(\frac{S_T Tg}{\sqrt{2\pi}\lambda N_0}\right)^2\right)}{2gS_T T/N_0}, \frac{S_{max}}{S_T}\right) \times F_G(g) dg = 1 \quad (21)$$

Thus, substituting (13) in (20) and (20) in (11) subsequently, yields the optimal transmitter weights that minimize the average BER. Finally, substituting (20) in (12), we get the average BER with the optimal weighting scheme as

$$\bar{P}_b = \int_0^\infty Q\left(\sqrt{\frac{2S_T Tg}{N_0}} \times \sqrt{\min\left(\frac{W\left(\left(\frac{S_T Tg}{\sqrt{2\pi}\lambda N_0}\right)^2\right)}{2gS_T T/N_0}, \frac{S_{max}}{S_T}\right)}\right) F_G(g) dg \quad (22)$$

IV. Numerical Results and Discussions

Fig. 2 depicts the average BER in (22) versus $S_T T/N_0$ for several values of peak-to-average power ratio S_{max}/S_T . In order to evaluate $W(\cdot)$ numerically, we used Maple^[20], a mathematics software package. Efficient techniques for numerical evaluation of $W(\cdot)$ are also available in^[21,22]. We note that the MRT³ scheme corresponds to the special case of $P=1$ in (11), consequently involves the peak-to-average power ratio of 0 dB. We can see that the BER curves with higher $S_T T/N_0$ and/or larger M are affected much more by the peak transmit power limit. This indicates that, as the available average transmit power and/or the number of transmit antennas increase, the optimal weighting method requires a power amplifier with higher peak-to-average power ratio. For lower peak-to-average power ratio, the performance gain

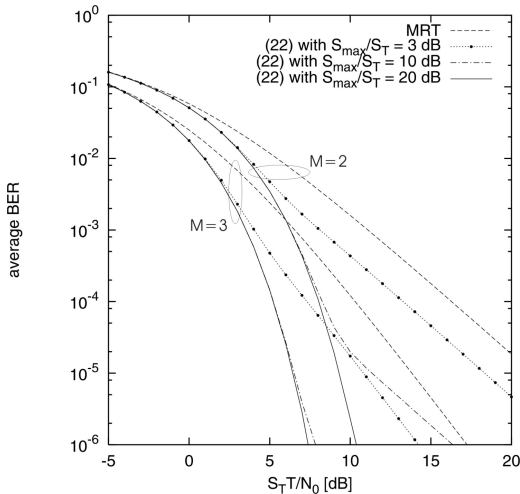

Fig. 2. Average BER versus $S_T T/N_0$

provided by the optimal transmitter weights becomes marginal, since the dynamic allocation of available transmit power in the time domain is restricted by lower S_{max}/S_T .

In 3G wireless systems^[1], the TAD is mostly adopted at the base station (BS), because it is cost effective and practical to employ multiple transmit antennas at BS rather than at the mobile station (MS). The power amplifier employing at BS can have relatively higher peak-to-average power ratio than that at MS. Therefore, the TAD in the downlink can not be affected by the peak transmit power limit on the most practical range of system parameters. However, the implementation of multiple antennas at MS is a considerable demand for high-performance next generation wireless communications^[23,24]. The TAD in the uplink is required to design the transmission parameters cautiously due to its substantial limitation on the peak-to-average power ratio at the MS.

V. Conclusion

We have investigated the effect of limited peak power on the performance of a closed-loop transmit antenna diversity system. We have derived a closed-form expression for the optimal transmitter weights that minimize the average

BER subject to average and peak transmit power constraints. It was found that the peak power limitation degrades the average BER more significantly as the available average power and/or the number of transmit antennas increase.

References

- [1] R. T. Derryberry, S. D. Gray, D. M. Ionescu, G. Mandyam, and B. Raghothaman, "Transmit diversity in 3G CDMA systems," *IEEE Commun. Mag.*, pp. 68-75, Apr. 2002.
- [2] T. Lo, "Maximum ratio transmission," *IEEE Trans. Commun.*, vol. 47, pp. 1458-1461, Oct. 1999.
- [3] J. K. Cavers, "Single-user and multiuser adaptive maximal ratio transmission for Rayleigh channels," *IEEE Trans. Veh. Technol.*, vol. 49, pp. 2043-2050, Nov. 2000.
- [4] J. Choi, "Performance analysis for transmit antenna diversity with/without channel information," *IEEE Trans. Veh. Technol.*, vol. 51, pp. 101-113, Jan. 2002.
- [5] A. F. Naguib, A. Paulraj, and T. Kailath, "Capacity improvement with base station antenna arrays in cellular CDMA," *IEEE Trans. Veh. Technol.*, vol. 43, pp. 691-698, Aug. 1994.
- [6] F. Rashid-Farrokhi, L. Tassiulas, and K. Liu, "Joint optimal power control and beamforming in wireless networks using antenna arrays," *IEEE Trans. Commun.*, vol. 46, pp. 1313-1324, Oct. 1998.
- [7] F. Rashid-Farrokhi, K. Liu, and L. Tassiulas, "Transmit beamforming and power control for cellular wireless systems," *IEEE J. Select. Areas Commun.*, vol. 16, pp. 1437-1450, Oct. 1998.
- [8] M. Schubert and H. Boche, "An efficient algorithm for optimum joint downlink beamforming and power control," in *Proc. IEEE VTC spring*, pp. 1911-1915, May 2002.
- [9] M. Schubert, D. Karadoulamas, H. Boche, and G. Lehmann, "Joint downlink beamforming

- and power control for 3G CDMA,” in Proc. *IEEE VTC spring*, pp. 331-335, Apr. 2003.
- [10] A. J. Goldsmith and P. P. Varaiya, “Capacity of fading channels with channel side information,” *IEEE Trans. Inform. Theory*, vol. 43, pp. 1986-1992, Nov. 1997.
- [11] A. J. Goldsmith and S. G. Chua, “Variable-rate variable-power MQAM for fading channels,” *IEEE Trans. Commun.*, vol. 45, pp. 1218-1230, Oct. 1997.
- [12] R. Knopp and G. Caire, “Power control and beamforming for systems with multiple transmit and receive antennas,” *IEEE Trans. Wireless Commun.*, vol. 1, pp. 638-648, Oct. 2002.
- [13] S. T. Chung and A. J. Goldsmith, “Degrees of freedom in adaptive modulation: a unified view,” *IEEE Trans. Commun.*, vol. 49, pp. 1561-1571, Sep. 2001.
- [14] E. N. Onggosanusi, A. Gatherer, A. Dabak, and S. Hosur, “Performance analysis of closed-loop transmit diversity in the presence of feedback delay,” *IEEE Trans. Commun.*, vol. 49, pp. 1618-1630, Sep. 2001.
- [15] M. Schwartz, W. R. Bennett, and S. Stein, *Communication Systems and Techniques*. New-York: McGraw-Hill, 1966.
- [16] J. G. Proakis, *Digital Communications*. McGraw-Hill, 3rd. ed., 1995.
- [17] G. S. G. Beveridge and R. S. Schechter, *Optimization: Theory and Practice*. McGraw-Hill, 1970.
- [18] Y. H. Lee, *Power and rate adaptation in CDMA communications*. PhD thesis, Inform. Transmission Lab., Korea Adv. Inst. Science and Technol. (KAIST), Daejeon, Korea, Feb. 2000.
- [19] R. M. Corless, G. H. Gonnet, D. E. G. Hare, D. J. Jeffrey, and D. E. Knuth, “On the Lambert W function,” *Adv. Computat. Math.*, vol. 5, pp. 329-359, 1996.
- [20] A. Heck, *Introduction to Maple*. Springer-Verlag, 1993.
- [21] D. A. Barry, P. J. Culligan-Hensley, and S. J. Barry, “Real values of the W-function,” *ACM Trans. Math. Software*, vol. 21, pp. 161-171, 1995.
- [22] D. A. Barry, J.-Y. Parlange, L. Li, H. Prommer, C. J. Cunningham, and F. Stagnitti, “Analytical approximations for real values of the Lambert W-function,” *Math. Comput. Simul.*, vol. 53, pp. 95-103, 2000.
- [23] Y. Kim et al., “Beyond 3G: vision, requirements, and enabling technologies,” *IEEE Commun. Mag.*, vol. 41, pp. 120-124, Mar. 2003.
- [24] H. Sampath, S. Talwar, J. Tellado, V. Erceg, and A. Paulraj, “A fourth-generation MIMO-OFDM broadband wireless system: design, performance, and field trial results,” *IEEE Commun. Mag.*, vol. 40, pp. 143-149, Sep. 2002.

이 예 훈 (Ye Hoon Lee)

정회원

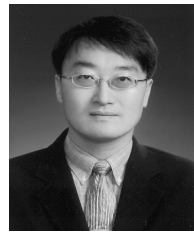

2000년 2월 한국과학기술원 전기 및 전자공학과 박사

1994년 7월~1997년 12월 한국 전자통신연구원 위촉연구원

2000년 7월~2001년 7월 LG 전자 선임연구원

2001년 8월~2002년 12월 Research Associate, New Jersey Institute of Technology, Newark, USA

2004년 3월~2004년 6월 Visiting Scholar, Stanford University, Palo Alto, USA

2003년 3월~2005년 9월 삼성종합기술원 Communication & Network Lab. 전문연구원

2005년 10월~현재 서울산업대학교 전자정보공학과 교수

<관심분야> 이동 통신, 통신 이론, 초 광대역 통신, 적응 변복조 등