

New Cyclic Precoding Vectors for Open-loop Transmit Diversity Techniques

Kyoung-Jae Lee*, Heunchul Lee** *Regular Members*, Inkyu Lee* *Lifelong Member*

ABSTRACT

In this paper, we propose a new transmit diversity technique for multiple-input multiple-output (MIMO) systems to improve the link level performance of open-loop systems. By cyclically applying a predetermined set of precoding weight vectors, artificially induced fluctuation is created to achieve additional diversity gain in flat fading channels. To design the set of the precoding vectors, we exploit the knowledge on the distribution of near optimum precoding vectors observed in a beamforming scheme based on the rotation transformations. Simulation results demonstrate that the proposed open-loop diversity scheme with an arbitrary number of transmit antennas achieves a full diversity gain with computational complexity comparable to a single-input single-output (SISO) system.

Key Words : Transmit antenna diversity, Channel coding

I. Introduction

Wireless multiple-input multiple-output (MIMO) systems provide increased capacity as the number of antennas grows. The capacity analysis of MIMO systems has shown significant gains over single antennas systems^{[1],[2]}. The expected benefits include higher system capacity and improved quality of service as a result of spatial multiplexing (SM) and diversity gain. In this paper, we focus on diversity gain using multiple transmit antennas.

A scheme with multiple transmit antennas at the base station is a convenient method to obtain the diversity gain, since mobile users are often equipped with a limited number of antennas in practical wireless communication systems. In open-loop systems where channel state information (CSI) is known only at the receiver, a number of techniques exist for achieving the diversity gain from the transmit antennas such as antenna hopping^[3] and space-time block coding^[4]. Time diversity can be

created by inducing spatial selectivity in the case of the antenna hopping scheme, where a bit-interleaved coded modulation (BICM) structure^[5] is used to obtain the diversity gain. Space-time block codes (STBC) which achieve full transmit diversity with single-symbol decodable complexity have been designed for the two transmit antenna case in [6]. For the case with three or more transmit antennas, the transmission rate of the STBC from complex orthogonal designs is limited to $3/4$ or lower^{[7],[8]}. The code rate can be made higher by sacrificing either full diversity or single-symbol decodability. A design of quasi-orthogonal STBC (QO-STBC) is such a case made at the expense of single-symbol decodability and the diversity order [9]. Recently, it has been shown that the diversity property of QO-STBC can be improved by rotating the constellations of the symbols^{[10],[11]}. Also, a scheme which allows single-symbol decodability has been proposed by adopting rotation transformations^[12].

※ This research was supported by the MKE(Ministry of Knowledge Economy), Korea, under the ITRC(Information Technology Research Center) support program supervised by the IITA(Institute for Information Technology Advancement)(IITA-2008-C1090-0801-0013).

* 고려대학교 전기전자전파공학부 무선통신 연구실(kyoungjae@korea.ac.kr, inkyu@korea.ac.kr)

** 스탠포드대학교 전자공학과(heunchul@stanford.edu)

논문번호 : KICS2008-12-531, 접수일자 : 2008년 12월 1일, 최종논문접수일자 : 2009년 4월 1일

In this paper, we propose a new open-loop diversity scheme using the predetermined precoding set based on the rotation transformations proposed in [13]. The basic concept is similar to the antenna hopping scheme^[14] which makes an artificial time selective channel over flat fading channels. In order to generate time selectivity, our proposed scheme adopts the predetermined set of the precoding weight vectors known at both the transmitter and receiver. In the proposed scheme, a diversity gain can be achieved by maximizing fluctuations of the effective channels after precoding. Hence, it is the principal goal of the paper to identify the efficient precoding weight vectors. We design the set of precoding weight vectors by utilizing the distribution of the rotation angles used in the beamforming scheme in [13]. Simulation results confirm that the proposed open-loop diversity scheme is able to achieve the full diversity gain for an arbitrary number of transmit antennas. Furthermore, the computational complexity for the proposed scheme is comparable to a single-input single-output (SISO) system.

This paper is organized as follows: Section II describes the system model for the transmit beamforming scheme. In Section III, we review the beamforming scheme based on rotation transformations in limited feedback systems. In Section IV, a new open-loop diversity scheme using the set of the precoding weight vectors is proposed. Section V shows the simulation results and compares the proposed method with other transmit diversity schemes. Finally, the paper is terminated with conclusions in Section VI.

II. System Descriptions

In this section, we consider general beamforming MIMO systems with M_t transmit and M_r receive antennas, as shown in Figure 1. In this figure, the BICM structure^[5] is employed, and we assume that one frame consists of K complex symbols. In the receiver structure, maximum ratio combining (MRC) is adopted. A data bit stream is coded, interleaved, and modulated to produce a complex data symbol

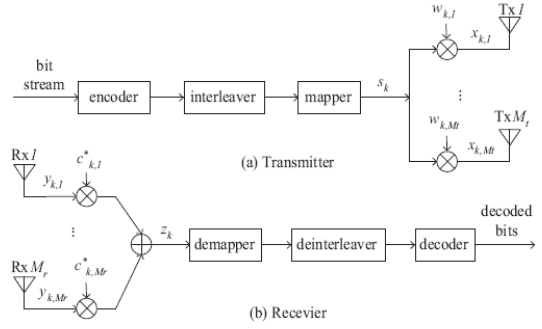

Fig. 1. Schematic diagram of a transmit beamforming and receive combining scheme for M_t transmit and M_r receive antennas

sequence s_k ($1 \leq k \leq K$). The k th modulated data symbol s_k is weighted with a unit-norm beamforming weight vector $\mathbf{w}_k = [w_{k,1} \cdots w_{k,M_t}]^T$ ($\|\mathbf{w}_k\| = 1$) to form the M_t dimensional complex transmitted signal vector $\mathbf{x}_k = [x_{k,1} \cdots x_{k,M_t}]^T$, i.e., $\mathbf{x}_k = \mathbf{w}_k s_k$, where \mathbf{w}_k is the M_t dimensional complex column vector and $\|\cdot\|$ denotes the Euclidean norm. The elements of the k th signal vector \mathbf{x}_k are then distributed through M_t transmit antennas.

We denote \mathbf{H} and \mathbf{y}_k as the M_r by M_t channel matrix and the M_r dimensional complex vector of the k th received signal, respectively. Then, the received signal vector \mathbf{y}_k for $k = 1, 2, \dots, K$ is given as

$$\mathbf{y}_k = [y_{k,1} \ y_{k,2} \ \cdots \ y_{k,M_r}]^T = \mathbf{H}\mathbf{x}_k + \mathbf{n}_k \quad (1)$$

where \mathbf{n}_k is an independent and identically distributed (i.i.d) complex Gaussian noise vector with the covariance matrix $\sigma_n^2 \mathbf{I}_{M_r}$. Here \mathbf{I}_d indicates an identity matrix of size d . We assume that the elements of the MIMO channel matrix \mathbf{H} are obtained from an i.i.d complex Gaussian distribution. The channel is assumed to be flat fading and fixed during one frame, and varies independently from frame to frame. The channel response matrix \mathbf{H} can be defined as

$$\mathbf{H} = [\mathbf{h}_1 \mathbf{h}_2 \cdots \mathbf{h}_{M_t}]$$

where \mathbf{h}_i is defined as the i th column vector of the channel response matrix \mathbf{H} .

In the receiver, the k th combining vector \mathbf{c}_k is given as $\mathbf{c}_k = [c_{k,1} \cdots c_{k,M_r}]^T = \mathbf{H}\mathbf{w}_k / \|\mathbf{H}\mathbf{w}_k\|$ by MRC which is optimal in a signal-to-noise ratio (SNR) sense. By combining the received signal vector \mathbf{y}_k with \mathbf{c}_k , the corresponding estimated symbol z_k for $k = 1, 2, \dots, K$ can be written as

$$z_k = \mathbf{c}_k^H \mathbf{y}_k = \|\mathbf{H}\mathbf{w}_k\| s_k + \mathbf{c}_k^H \mathbf{n}_k \quad (2)$$

where $(\cdot)^H$ denotes the complex conjugate transpose of a vector or matrix.

Then, the maximum-likelihood (ML) estimate of the transmitted symbol s_k is given by

$$\hat{s}_k = \underset{s_k \in Q_c}{\operatorname{argmin}} |z_k - \|\mathbf{H}\mathbf{w}_k\| s_k| \quad (3)$$

where Q_c denotes a signal constellation and $|\cdot|$ represents the magnitude.

Note that in the closed-loop system, the channel gain $\mathbf{c}_k^H \mathbf{H}\mathbf{w}_k$ is maximized when the dominant right singular vector of the channel matrix \mathbf{H} corresponding to the largest singular value is employed as the weight vector \mathbf{w}_k [14]. In contrast, in the case of open-loop systems, it is not possible to use the optimum weight vector since the transmitter has no CSI of the channel \mathbf{H} . In this paper, we propose a transmit diversity scheme which employs a predetermined set of the precoding weight vectors. For open-loop systems, we first construct the set of the precoding weight vectors known at both the transmitter and receiver. The weight vectors in the predetermined set are cyclically applied at the transmitter in each frame. An efficient design of weight vectors is important to maximize the diversity gain in open-loop systems. In the following section, we will review a closed-loop beamforming scheme based on the rotation transformations which achieves the performance close to the optimum

beamforming. Based on this scheme, we develop a new open-loop system by utilizing the observations made in the closed-loop scheme.

III. Transmit Beamforming based on Rotation Transformations

In this section, we consider a transmit beamforming based on rotation transformations presented in [13] for closed-loop MIMO systems to orthogonalize two column vectors of the channel. Note that we can increase the channel gain using the fact that the norm of a column is maximized when the column becomes orthogonal to the other columns in the channel matrix^{[15],[16]}. Hence, we concentrate on the precoding matrix to orthogonalize the column vectors of the channel matrix \mathbf{H} .

Given two column vectors \mathbf{h}_i and \mathbf{h}_j in \mathbf{H} , the Hermitian product of the two complex-valued vectors is defined by [13]

$$\langle \mathbf{h}_i, \mathbf{h}_j \rangle = \mathbf{h}_i^H \mathbf{h}_j = \langle \mathbf{h}_i, \mathbf{h}_j \rangle_R + j \langle \mathbf{h}_i, \mathbf{h}_j \rangle_I \quad (4)$$

where $\langle \cdot, \cdot \rangle_R$ and $\langle \cdot, \cdot \rangle_I$ denote the real part and the imaginary part of $\langle \cdot, \cdot \rangle$, respectively.

Two rotation transformations were introduced in [13] which make this Hermitian product zero so as to maximize the channel gain. First, we consider the following transformation

$$[\tilde{\mathbf{h}}_i, \tilde{\mathbf{h}}_j] = [\mathbf{h}_i, \mathbf{h}_j] \mathbf{I}(\theta) \quad (5)$$

where $\mathbf{I}(\theta)$ denotes the *inner* rotation matrix given as

$$\mathbf{I}(\theta) = \begin{bmatrix} \cos \theta & \sin \theta \\ -\sin \theta & \cos \theta \end{bmatrix}.$$

We define the condition $\langle \tilde{\mathbf{h}}_i, \tilde{\mathbf{h}}_j \rangle_R = 0$ as *inner orthogonal* [13], which can be satisfied by the rotation angle

$$\theta_{ij} = \tan^{-1} \left(\frac{A - \sqrt{A^2 + 4B^2}}{2B} \right) \quad (6)$$

where $A = \|\mathbf{h}_i\|^2 - \|\mathbf{h}_j\|^2$ and $B = \langle \mathbf{h}_i, \mathbf{h}_j \rangle_R$.

Next, the condition $\langle \tilde{\mathbf{h}}_i, \tilde{\mathbf{h}}_j \rangle_I = 0$ is referred to as *outer orthogonal* [13]. In order to make two complex column vectors outer orthogonal, we need to employ the rotation operation as

$$[\tilde{\mathbf{h}}_i, \tilde{\mathbf{h}}_j] = [\mathbf{h}_i, \mathbf{h}_j] \mathbf{O}(\theta) \quad (7)$$

where the *outer* rotation matrix $\mathbf{O}(\theta)$ is defined as

$$\mathbf{O}(\theta) = \begin{bmatrix} \cos\theta & j\sin\theta \\ j\sin\theta & \cos\theta \end{bmatrix}.$$

Here, the rotation angle to achieve the outer orthogonality is obtained as

$$\theta_o^{ij} = \tan^{-1} \left(\frac{A - \sqrt{A^2 + 4\tilde{B}^2}}{2\tilde{B}} \right) \quad (8)$$

where $\tilde{B} = \langle \mathbf{h}_i, \mathbf{h}_j \rangle_I$.

We note again that with the above rotation angles, the norm of $\tilde{\mathbf{h}}_i$ is maximized while minimizing the norm of $\tilde{\mathbf{h}}_j$ in (5) and (7). It is straightforward to verify that these rotation transformations are unitary.

Furthermore, in (4), the Hermitian product becomes zero by the transformation $\mathbf{I}(\theta_I^{ij})\mathbf{O}(\theta_c^{ij})$ with

$$\theta_c^{ij} = \tan^{-1} \left(\tilde{A} - \frac{\sqrt{\tilde{A}^2 + 4\tilde{B}^2}}{2\tilde{B}} \right)$$

where $\tilde{A} = \sqrt{A^2 + 4B^2}$. Thus, this transformation can achieve the optimum beamforming gain.

In [13], it has been shown that most gain of the optimum beamforming can be realized by selecting one of two rotation matrices for the precoding matrix \mathbf{P} according to the following criterion:

$$\mathbf{P} = \begin{cases} \mathbf{I}(\theta_I^{ij}), & \text{if } |\langle \mathbf{h}_i, \mathbf{h}_j \rangle_R| \geq |\langle \mathbf{h}_i, \mathbf{h}_j \rangle_I| \\ \mathbf{O}(\theta_o^{ij}), & \text{if } |\langle \mathbf{h}_i, \mathbf{h}_j \rangle_R| \leq |\langle \mathbf{h}_i, \mathbf{h}_j \rangle_I| \end{cases} \quad (9)$$

This criterion is a direct consequence of the fact that the inner rotation operation annihilates the real part $\angle \langle \mathbf{h}_i, \mathbf{h}_j \rangle_R$ of Equation

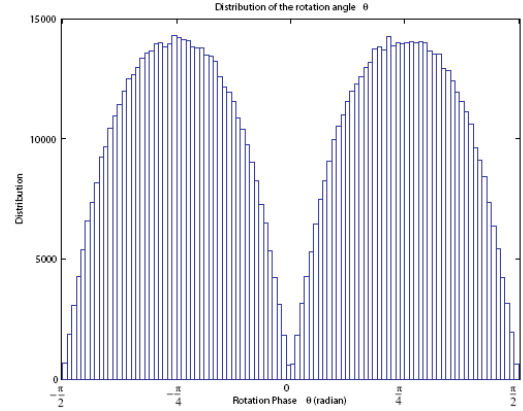

Fig. 2. The distribution of the rotation angles used in the selected transformation after selecting one of two rotation transformations

($\text{ref}\{eq:hermitian\}$) while the outer rotation operation is used to nullify the imaginary part $\langle \mathbf{h}_i, \mathbf{h}_j \rangle_I$.

While the rotation angles θ_I^{ij} and θ_o^{ij} in (6) and (8) have a uniform distribution over $-\pi/2 \leq \theta \leq \pi/2$, the angles of the selected rotation transformation in (9) are no longer uniformly distributed. The distribution of the rotation angle is found by a numerical search as shown in Figure 2. This plot illustrates that the distribution of the rotation angle is concentrated around the value near $\pi/4$ or $-\pi/4$. Therefore, the rotation transformation with $\pi/4$ or $-\pi/4$ may achieve a good channel gain for open loop systems. Motivated by this observation on the distribution of the angles of rotation transformation, we will design the precoding weight set in the following section.

IV. A New Transmit Diversity Scheme based on Cyclic Precoding Weight Vector

In this section, we propose a new transmit diversity scheme with the set of precoding weight vectors to artificially create selective fading. The predetermined set of precoding vectors is produced by utilizing the observation made in the previous section that the distribution of the angles used in the rotation transformations is concentrated on $\pm\pi/4$.

Denoting \mathbf{P}_k as the unitary precoding matrix for the k th symbol s_k , the beamforming weight vector

\mathbf{w}_k can be written as

$$\mathbf{w}_k = \mathbf{p}_i^k \quad (10)$$

where \mathbf{p}_i^k denotes the i th column of the matrix \mathbf{P}_k . Then, the k th received signal \mathbf{y}_k in (1) is given as

$$\mathbf{y}_k = \mathbf{H}\mathbf{w}_k s_k + \mathbf{n}_k = \mathbf{H}\mathbf{p}_i^k s_k + \mathbf{n}_k$$

In the case of $M_t = 2$, the precoding weight vector for the proposed scheme is determined as $\mathbf{w}_k = \mathbf{p}_1^k$, where the precoding matrix \mathbf{P}_k is cyclically given as one of four possible transformations $\mathbf{I}(\pi/4)$, $\mathbf{I}(-\pi/4)$, $\mathbf{O}(\pi/4)$ and $\mathbf{O}(-\pi/4)$. Thus, the precoding weight vectors with the period of 4 are obtained as in the table I.

To apply our scheme to the case of $M_t \geq 3$, we define the M_t by M_t inner transformation matrix as the form of

$$\mathbf{I}(i, \theta) = \begin{bmatrix} 1 & \cdots & 0 & 0 & \cdots & 0 \\ \vdots & \ddots & \vdots & \vdots & & \vdots \\ 0 & \cdots & \cos\theta & \sin\theta & \cdots & 0 \\ 0 & \cdots & -\sin\theta & \cos\theta & \cdots & 0 \\ \vdots & & \vdots & \vdots & \ddots & \vdots \\ 0 & \cdots & 0 & 0 & \cdots & 1 \end{bmatrix}$$

Here $\mathbf{I}(i, \theta)$ is an identity matrix with the exception of

$$\begin{aligned} [\mathbf{I}(i, \theta)]_{i,i} &= \cos\theta, \\ [\mathbf{I}(i, \theta)]_{i, \langle i \rangle_{M_t} + 1} &= \sin\theta, \\ [\mathbf{I}(i, \theta)]_{\langle i \rangle_{M_t} + 1, i} &= -\sin\theta, \\ [\mathbf{I}(i, \theta)]_{\langle i \rangle_{M_t} + 1, \langle i \rangle_{M_t} + 1} &= \cos\theta \end{aligned}$$

where $[\cdot]_{i,j}$ denotes the (i, j) th element of a matrix and $\langle \cdot \rangle_{M_t}$ represents the modulo operation with M_t . In a similar way, the outer transformation $\mathbf{O}(i, \theta)$ is obtained. It is straightforward to show that the above two rotation matrices are unitary. These two operations will affect only columns i and $i + 1$ while leaving the rest of the matrix unchanged.

For $M_t \geq 3$, we employ the orthogonalization

process on the column pairs (i, j) of the channel matrix \mathbf{H} in the order of $(1, 2), (2, 3), \dots, (M_t - 1, M_t), (M_t, 1)$, which is called a sweep cycle. Therefore, one sweep cycle involves the orthogonalization of M_t columns pairs. By performing this sweeping, additional diversity gain is obtained from M_t columns of the channel matrix \mathbf{H} . For $M_t \geq 3$, the set of precoding weight vectors in (10) is then given as

$$\mathbf{w}_k = \mathbf{p}_{\left\lfloor \left\lfloor \frac{k-1}{4} \right\rfloor \right\rfloor_{M_t} + 1} \quad \text{for } k = 1, \dots, K \quad (11)$$

We adopt the $\left(\left\lfloor \left\lfloor \frac{k-1}{4} \right\rfloor \right\rfloor_{M_t} + 1 \right)$ th column of the k th unitary precoding matrix \mathbf{P}_k to rotate sweep cycles, where $\lfloor \cdot \rfloor$ denotes the floor operation. The unitary precoding matrix is given as

$$\mathbf{P}_k = \begin{cases} \mathbf{I} \left(\left\lfloor \left\lfloor \frac{k-1}{4} \right\rfloor \right\rfloor_{M_t} + 1, \frac{\pi}{4} \right), & \text{if } \langle k \rangle_4 = 1 \\ \mathbf{I} \left(\left\lfloor \left\lfloor \frac{k-1}{4} \right\rfloor \right\rfloor_{M_t} + 1, -\frac{\pi}{4} \right), & \text{if } \langle k \rangle_4 = 2 \\ \mathbf{O} \left(\left\lfloor \left\lfloor \frac{k-1}{4} \right\rfloor \right\rfloor_{M_t} + 1, \frac{\pi}{4} \right), & \text{if } \langle k \rangle_4 = 3 \\ \mathbf{O} \left(\left\lfloor \left\lfloor \frac{k-1}{4} \right\rfloor \right\rfloor_{M_t} + 1, -\frac{\pi}{4} \right), & \text{if } \langle k \rangle_4 = 4 \end{cases} \quad (12)$$

The unitary precoder in (12) cyclically adopts inner and outer rotation transformation matrices with the rotation angles $\pi/4$ and $-\pi/4$. After the selection of the unitary precoder based on the sweeping ordering (12), the precoding weight vector \mathbf{w}_k is determined as in (11). The precoding matrix \mathbf{P}_k for $M_t \geq 3$ has a period of $4M_t$. As an example, the set of precoding weight vectors for the proposed algorithm with four transmit antennas and a period of 16 is illustrated in Table II. The order of the cyclic beamforming pattern in the proposed algorithm can be randomly permuted since interleaving is employed in the BICM structure.

Note that the MRC receiver in (2) and (3) has the detector complexity comparable to a SISO system regardless of the number of transmit and receive antennas. The cyclical application of the precoding

TABLE I
THE PRECODING WEIGHT VECTORS FOR $M_t = 2$

k	1	2	3	4
w_k	$\frac{1}{\sqrt{2}}$ $\frac{-1}{\sqrt{2}}$	$\frac{1}{\sqrt{2}}$ $\frac{1}{\sqrt{2}}$	$\frac{1}{\sqrt{2}}$ $\frac{j}{\sqrt{2}}$	$\frac{1}{\sqrt{2}}$ $\frac{-j}{\sqrt{2}}$

TABLE II
THE PRECODING WEIGHT VECTORS FOR $M_t = 4$

k	1	2	3	4	5	6	7	8
w_k	$\frac{1}{\sqrt{2}}$ $\frac{-1}{\sqrt{2}}$ 0 0	$\frac{1}{\sqrt{2}}$ $\frac{1}{\sqrt{2}}$ 0 0	$\frac{1}{\sqrt{2}}$ $\frac{j}{\sqrt{2}}$ 0 0	$\frac{1}{\sqrt{2}}$ $\frac{-j}{\sqrt{2}}$ 0 0	0 $\frac{1}{\sqrt{2}}$ $\frac{-1}{\sqrt{2}}$ 0	0 $\frac{1}{\sqrt{2}}$ $\frac{1}{\sqrt{2}}$ 0	0 $\frac{1}{\sqrt{2}}$ $\frac{j}{\sqrt{2}}$ 0	0 $\frac{1}{\sqrt{2}}$ $\frac{-j}{\sqrt{2}}$ 0
k	9	10	11	12	13	14	15	16
w_k	0 0 $\frac{1}{\sqrt{2}}$ $\frac{-1}{\sqrt{2}}$	0 0 $\frac{1}{\sqrt{2}}$ $\frac{1}{\sqrt{2}}$	0 0 $\frac{1}{\sqrt{2}}$ $\frac{j}{\sqrt{2}}$	0 0 $\frac{1}{\sqrt{2}}$ $\frac{-j}{\sqrt{2}}$	$\frac{-1}{\sqrt{2}}$ $\frac{1}{\sqrt{2}}$ 0 $\frac{1}{\sqrt{2}}$	$\frac{1}{\sqrt{2}}$ $\frac{1}{\sqrt{2}}$ 0 $\frac{1}{\sqrt{2}}$	$\frac{j}{\sqrt{2}}$ 0 $\frac{1}{\sqrt{2}}$ $\frac{1}{\sqrt{2}}$	$\frac{-j}{\sqrt{2}}$ 0 $\frac{1}{\sqrt{2}}$ $\frac{1}{\sqrt{2}}$

weight vectors given in (11) and (12) can be easily done to any antenna configurations without modification of the transmit structure. Consequently, the proposed scheme with the precoding vector set can offer a diversity gain for an arbitrary number of transmit antennas in open-loop systems.

V. Simulation Results

In this section, we present simulation results for the proposed transmit diversity scheme in flat fading channels and compare them with conventional systems such as the STBC and the antenna hopping scheme. The constellations used are M -QAM with M constellation points. Hence, the spectral efficiency of the proposed system is $R_T = R_C \cdot \log_2 M$ bps/Hz while that of the STBC system is given as $R_T = (R_C \cdot M_t \cdot \log_2 M) / 2$ bps/Hz, where R_C denotes the rate of the convolutional code and T represents the block period for the STBC. In our simulation, the STBC systems with full rate ($T = M_t$) are considered to make a fair comparison with the proposed system. Throughout the paper, we use 16QAM constellation ($M = 16$) with gray mapping and employ a convolutional encoder of rate $1/2$ with polynomials (133,171) in octal notation. The symbol length K in one frame is set to 128 and 256, and a pseudo random interleaver is used.

In Figure 3, the proposed scheme is compared to

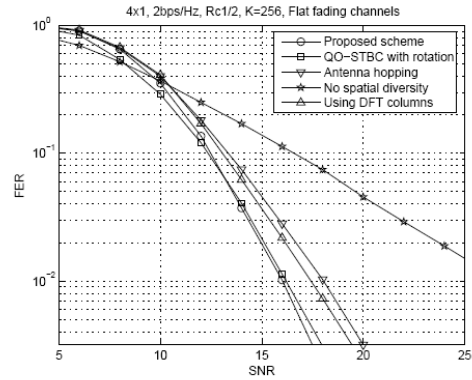

Fig. 3. Frame-error-rate performance comparison for four transmit and one receive antennas

the conventional schemes with four transmit antennas. The plot shows that the proposed scheme outperforms the antenna hopping method and the scheme utilizing the columns of a discrete Fourier transform (DFT) matrix by 2dB and 1.5dB at a frame error rate (FER) of 10^{-2} , respectively. Here the antenna hopping scheme can be considered as a special case of the proposed scheme where an identity matrix is used as a precoding matrix, i.e., $P_k = I_{M_t}$ in (12). This figure exhibits no performance gap between the proposed method and the QO-STBC scheme with rotated constellation [10] at a FER of 10^{-2} . The QO-STBC is full rate, but requires a joint ML detection for two symbols. Thus, the QO-STBC with constellation rotation has much higher decoding complexity compared with the proposed diversity scheme. In this simulation, the demapper of the QO-STBC system needs to search $16^2 = 256$ candidates to compute the log-likelihood ratio (LLR) value, whereas only 16 candidates are to be searched for the proposed scheme.

When the number of transmit antennas increases, the performance gain of the proposed scheme becomes more pronounced. In Figure 4, we plot the diversity gain of the proposed scheme for various numbers of transmit antennas. In this figure, the dotted lines show the MRC scheme performance where the SNR penalty of $10 \log_{10} M_t$ (dB) is included to account for the array gain of a receiver

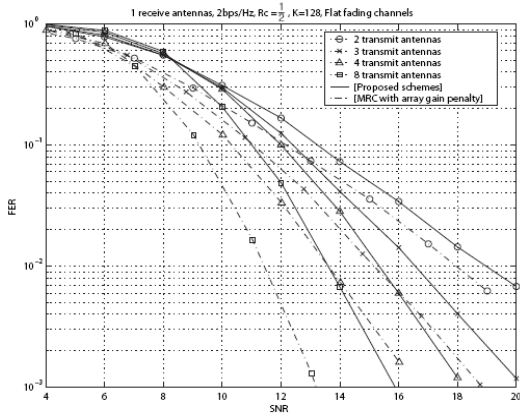

Fig. 4. Frame-error-rate performance comparison for various transmit and one receive antennas

diversity scheme over a transmit diversity scheme. We can see that the diversity order of the proposed scheme is the same as that of the corresponding MRC scheme for different numbers of transmit antennas. Furthermore, the proposed transmit diversity scheme has the detection complexity comparable to a SISO system for all antenna configurations since the proposed system employs a beamforming scheme with only one data stream and an MRC receiver.

VI. Conclusion

We have proposed a new open-loop transmit diversity scheme based on the precoding weight vector set. The precoding weight vectors used in our scheme are built up based on the selection scheme between the inner rotation and outer rotation to make two complex-valued vectors orthogonal. We have noticed that the rotation angles of the rotation transformations are concentrated on $\pm\pi/4$ after selecting one of two rotation transformations. The proposed transmit diversity scheme cyclically assigns two rotation transformations and two rotation angles $\pm\pi/4$. The simulation results demonstrate that the proposed scheme is quite effective in achieving the full diversity order for an arbitrary number of transmit antennas with single decodable ML detection.

Reference

- [1] G. J. Foschini and M. Gans, "On Limits of Wireless Communications in a Fading Environment when Using Multiple Antennas," *Wireless Personal Communications*, vol. 6, pp. 311 - 335, March 1998.
- [2] I. E. Telatar, "Capacity of multi-antenna Gaussian channels," *Eur. Trans. Telecom.*, vol. 10, pp. 585 - 595, November 1999.
- [3] H. Olofsson, M. Almgren, and M. Hookin, "Transmitter diversity with antenna hopping for wireless communication systems," in *Proc. IEEE VTC'06*, vol. 3, pp. 1743 - 1747, May 1997.
- [4] V. Tarokh, H. Jafarkhani, and A. R. Calderbank, "Space-time block codes from orthogonal designs," *IEEE Transactions on Information Theory*, vol. 45, pp. 1456 - 1467, July 1999.
- [5] G. Caire, G. Taricco, and E. Biglieri, "Bit-Interleaved Coded Modulation," *IEEE Transactions on Information Theory*, vol. 44, pp. 927 - 946, May 1998.
- [6] S. M. Alamouti, "A simple transmit diversity technique for wireless communications," *IEEE Journal on Selected Areas in Communications*, pp. 1451 - 1458, October 1998.
- [7] V. Tarokh, N. Seshadri, and A. R. Calderbank, "Space-time block coding for wireless communications: performance results," *IEEE Journal on Selected Areas in Communications*, vol. 17, pp. 451 - 460, March 1999.
- [8] O. Tirkkonen and A. Hottinen, "Square-Matrix Embeddable Space-Time Block Codes for Complex Signal Constellations," *IEEE Transactions on Information Theory*, vol. 48, pp. 384 - 394, February 2002.
- [9] H. Jafarkhani, "A quasi orthogonal space-time block code," *IEEE Transactions on Communications*, vol. 49, pp. 1 - 4, January 2001.
- [10] N. Sharma and C. Papadias, "Improved quasi-orthogonal codes through constellation rotation," *IEEE Transactions on Communications*,

vol. 51, pp. 332 - 335, March 2003.

- [11] W. Su and X.-G. Xia, "Signal Constellation for Quasi-Orthogonal Space-Time Block Codes With Full Diversity," *IEEE Transactions on Information Theory*, vol. 50, pp. 2331 - 2347, October 2004.
- [12] H. Lee, J. Cho, J.-K. Kim, and I. Lee, "An Efficient Decoding Algorithm for STBC with Multidimensional Rotated Constellations," in *Proc. ICC'06*, vol. 12, pp. 5558 - 5563, June 2006.
- [13] H. Lee, S. Park, and I. Lee, "A New MIMO Beamforming Technique Based on Rotation Transformations," in *Proc. IEEE ICC '07*, pp. 5359 - 5364, June 2007.
- [14] P. A. Dighe, R. K. Malik, and S. S. Jamuar, "Analysis of Transmit-Receive Diversity in Rayleigh Fading," *IEEE Transactions on Communications*, vol. 51, pp. 694 - 703, April 2003.
- [15] G. H. Golub and C. F. V. Loan, *Matrix Computations*. Third Edition, The Johns Hopkins University Press, Baltimore and London, 1996.
- [16] J. C. Nash, "A One-sided Transformation Method for the Singular Value Decomposition and Algebraic Eigenproblem," *The Computer Journal*, vol. 18(1), pp. 74 - 76, February 1975.

이 경 재 (Kyoung-Jae Lee)

정회원



2005년 8월 고려대학교 전기자
전파공학부 졸업
2007년 8월 고려대학교 전자전
기공학과 석사
2007년 9월~현재 고려대학교
전자전기공학과 박사과정
<관심분야> Signal processing
and coding theory for wireless communication

이 훈 철 (Heuncul Lee)

정회원



2003년 2월 고려대학교 전기공
학과 졸업
2005년 2월 고려대학교 전파공
학과 석사
2008년 2월 고려대학교 전자전
기공학과 박사
2008년 3월~10월 동대학원 박

사후 과정

2008년 11월~현재 스탠포드대학교 전자공학과 박사
후 과정
<관심분야> Signal processing and coding theory
for wireless communication

이 인 규 (Inkyu Lee)

종신회원



1990년 2월 서울대학교 제어계
측공학과 졸업
1992년 2월 스탠포드대학교 전
자공학과 석사
1995년 2월 스탠포드대학교 전
자공학과 박사
2002년 9월~현재 고려대학교 전

기전자전파공학부 정교수

<관심분야> Digital communication, signal processing
and coding technique applied to wireless
communication