

# VLC 시스템을 위한 협동 통신을 이용한 링크 복구 방식

정회원 레 투 안 남\*, 종신회원, 최 선 응\*, 장 영 민\*

## Link Recovery Scheme Using Cooperative Communication for VLC System

Nam-Tuan Le\* *Associate Member*, Sunwoong Choi\*, Yeong Min Jang\* *Lifelong Members*

### ABSTRACT

In Visible Light Communication (VLC) system, with the limitation of transmission range and Field Of View (FOV), LOS (Line of Sight) link between two transceivers should be guaranteed due to the straightness of the visible-light signal. Especially for indoor applications, link recovery is an advantage method to remain the link connection because of the link failure in which caused by movement obstacle. Link recovery schemes try to keep link dynamically without re-initialing connection. This article proposes a new link recover scheme for VLC system by using cooperative communication. Our propose scheme focuses on the QoS reservation resource by GTS in IEEE 802.15.7 specification in which the requested QoS resource from client should be guarantee during the application time. With the link recovery scheme, we will try to continue the link connection as long as possible when unexpected disconnect link. The mathematical analysis and simulation results show that proposed scheme increases the overall reliability of the VLC system.

**Key Words** : Link recovery, LED-ID, Cooperative Communication, VLC, IEEE 802.15.7

### I. Introduction

Visible LEDs become more efficient, have a high reliability and can be incorporated into many lighting applications. These sources can also be modulated at high-speed, offering the possibility of using sources for simultaneous illumination and data communications. With LOS (Line of Sight) communication between two VLC transceivers constitutes the majority of the applications, since the visible light cannot go through obstacles like a wall. However, the temporal blocking like walking people can cause burst frame errors, or even the link failure, and can occur frequently. In addition, the poor pointing of the VLC devices may cause the decrease of signal quality or even link

disconnection. Since VLC can be highly directional, it is difficult to re-establish link that has been lost due to movement or rotation of one of the devices in the link. Given such, it is necessary and important to have fast link recovery for VLC systems, for both point-to-point and point to-multipoint connections, yet the fast link recovery is very challenging<sup>[1]</sup>.

This paper presents fast and energy-efficient link recovery approaches for VLC system using cooperative communication. Cooperation comes as a new form of spatial diversity to overcome the limitation of wireless communication. In this technique, multiple nodes simultaneously receive, decode, and retransmit data packets. It improves the system performance by having a node(s), other than the source and the destination,

\* This research was supported by the Broadcasting-Communications R&D Program of Korea Communications Commission Agency (No 11911-01111).

\* Kookmin University, Korea, (namtuanlnt@gmail.com, schoi@kookmin.ac.kr, yjang@kookmin.ac.kr)  
논문번호 : KICS2011-11-643, 접수일자 : 2011년 12월 30일, 최종논문접수일자 : 2012년 4월 25일

actively help deliver data frame correctly to the destination. Cooperative communication technique shows the advantage in wireless networks especially the high fading and noise environment. The practice of cooperative communication can be embedded into the MAC protocol as follows. The data frame is transmitted by the source to the destination, while a third node(s) – the relay node(s) overhears the transmission of the data frame and may help improve the delivery success rate over the radio link.

This paper is structured as follows. The structure of VLC system and related works will be presented in section 2. New cooperative link recovery scheme for are shown in section 3. In this analysis, we focus on the performance of new scheme using cooperative communication base on IEEE 802.15.7 standard. Section 4 evaluates the performance of the proposed scheme and the improvement result from simulation. Finally, concluding remarks of the research results and contributions are given in section 5.

## II. Related Works

### A. Cooperative communication in VLC

In wireless communication, cooperative communication can be voted as a best promising technique to enhance system reliability and performances. Cooperation comes as a new form of spatial diversity to overcome the limitation of wireless communication. In this technique, multiple nodes simultaneously receive, decode, and retransmit data packets. The data frame is transmitted by the source to the destination, while a third node(s) – the relay node(s) overhears the transmission of the data frame and may help improve the delivery success rate over the radio link. The essence of the idea is that, the destination benefits from data frames arriving via two (or more ) statistically independent paths, i.e., spatial diversity. The sender and the receiver will choose some relay nodes for their cooperative communication. Multi-node cooperation enhances the throughput compared to single relay cooperation. If the primary link imposed by direct communication can offer enough bandwidth and QoS requirement, the conventional MAC is operated and no cooperative transmission is applied. Otherwise, the sender and destination receiver will initiate cooperative mechanism to find relay nodes for

cooperative communication.

There are many researches about MAC protocol for cooperative communication. References<sup>[2-4]</sup> proposed some cooperative MAC in wireless network. The key idea is to transmit a packet form a source node to the destination node via a helper node through a faster two-hop links rather than a lower one-hop direct link. This is possible due to a shorter distance between the source node and the helper node and a shorter distance between the helper node and the destination node as compared to the longer direct distance between the source node and the destination node.

### B. Link recovery survey

IEEE supports Fast link recovery for Part 15.7: short-range wireless optical communication using visible light in star topology and peer-to-peer topology. The fast link recovery process may be triggered at the device end during communication. The trigger may be initiated when the device does not receive ACKs for a number of times given by the MAC PIB attribute macNumAcks. In the fast link recovery process, the device may decide on its own to stop sending data. The device may also send the fast link recovery (FLR) signal repeatedly (within the allocated resource) to the coordinator if the device is connected to mains power. Upon receiving the FLR signal, the coordinator shall send a FLR response to the device. The communication resumes after the device receives the response. If there is bi-directional data transfer during communication, the device may wait after stopping sending data. If the device does not receive any FLR response signal within a timer given by the MAC PIB attribute macLinkTimeOut, the device may assume the link is broken and may disassociate.

“Efficient resource allocation for rapid link recovery and visibility in Visible-light local area networks” [6], proposed by Woo-Chan Kim, Chi-Sung Bae, Soo-Yong Jeon, Sung-Yeop Pyun, and Dong-Ho Cho, is a new protocol and scheme for visible light local area networks. The proposed MAC protocol is based on synchronous and time-slotted. A frame is divided into several timeslots. The durations of the frame and the slot are fixed. The VLAN system supports both full and half duplex modes. When AP detects the request resource, it allocates the dedicated mini-slot to the corresponding Mobile Node until it becomes disassociated with the AP. If the AP receives the first

signal at the dedicated mini-slot, it recognizes uplink synchronization and allocates resources for the association. If the AP does not receive signals at the dedicated slot for a fixed number of consecutive frames, it determines that the VLC link has become disconnected. When the AP determines the link is broken, it will transmit an UL-UNSYNC message to the MN. When the MN receives this message, it stops transmitting, apart from the status signal transmission at the dedicated mini-slot, until the AP receives the signal transmitted by the MN. In case of disconnection as a result of poor orientation, users must set up the direction of uplink signal to the AP receiver correctly. If the disconnected VLC link is recovered, and the AP can recognize uplink synchronization by the signal at the dedicated mini-slot, the AP transmits an UL-SYNC message to the MN. After the MN receives this message, it can then transmit data to the AP.

“Fast and Energy-Efficient link recovery in visible light communications”<sup>[7]</sup> is another proposes which focus on the link recovery problem. Their scheme based on traditional scheme with can support for and extended to multiple directions for different angles. For a device with multiple color bands, once fast link recovery is triggered at one color band, the device uses other color bands to send FLR signals to test links. This approach is useful for recover the links which are suffering the interference on different bands.

### III. Proposed Cooperative Link Recovery Scheme

The proposed cooperative MAC protocol<sup>[8]</sup> is based on the IEEE 802.15.7 MAC standard for short-range wireless optical communication using visible light. It exploits cooperative communication via multipoint relay to improve the reliable, throughput from source to destination. More detail, the sender and the receiver will choose some relay nodes for their cooperative communication. Multi-node cooperation enhances the throughput compared to single relay cooperation. When the link between the coordinator and client device is blocking by uncontrolled condition, the coordinator or client device will initiate cooperative mechanism to find relay nodes for cooperative communication link recovery. The scenarios of three communication techniques are shown in Fig. 1.

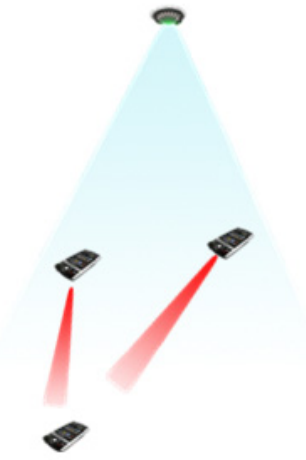

Fig. 1. LED-ID cooperative communication

The fast link recovery process may be triggered at the mobile node (MN) in the visible light communication. The trigger can be that the mobile node does not receive ACKs for a number of times given by a parameter N\_ACKS. In the fast link recovery process, the mobile node may decide on its own to stop sending data. The mobile node may optionally send fast link recovery (FLR) signal repeatedly (within the resource allocated) to the coordinator if the mobile node is plugged in with an adapter. Upon receiving the FLR signal, the coordinator sends a FLR response to the mobile node.

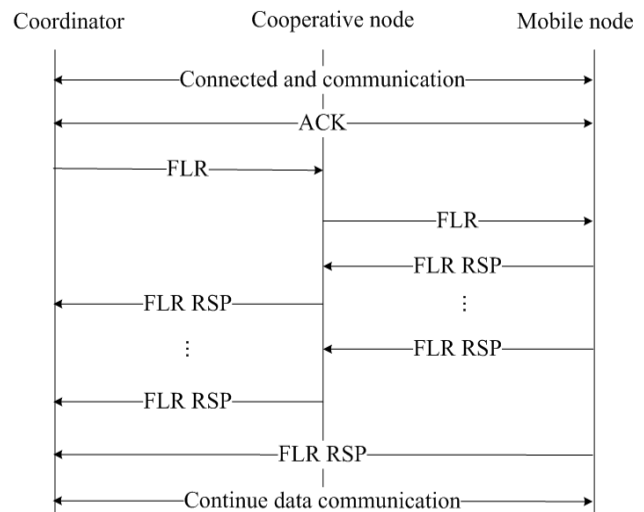

Fig. 2. Link recovery scheme using Cooperative communication from coordinator.

After device receives the response, the communication resumes. If there is both data service from the MN to

the coordinator and data service from the coordinator to the MN, the mobile node may wait after stopping data. If the mobile node does not receive any FLR response signal within a timer given by a parameter T\_LINKTIMEOUT, the mobile node may assume the LOS link is broken. In this time mobile node increase its FOV and send FLR signal again for NLOS link to the coordinator. Now the mobile node is ready to setup NLOS link to continue the resume communication. Upon receiving FLR signal for NLOS link, the coordinator sends a FLR response to the mobile node. After the mobile node receives the response, the communication resumes using NLOS link. If the mobile node does not receive any FLR response signal for NLOS link within a timer given by a parameter LINKTIMEOUT, the mobile node may assume the link is broken. The link recovery can also be triggered at the client. The process can be shown in Figure 3. When the client cannot receive ACKs for a number of times, the coordinator may stop sending data to the mobile node. The coordinator then sends fast link recovery (FLR) LOS signal repeatedly to the mobile node. The coordinator may hold the uplink grant allocated to the mobile node. Upon receiving FLR LOS signal, the mobile node will send a FLR response to the coordinator. After the coordinator receives the response, the communication resumes. If no FLR RSP is received by the coordinator wait a certain amount of time to receive NLOS RSP. Since the coordinator already stopped sending data therefore mobile node did not receive any data. This time mobile node goes to NLOS mode and sends NLOS RSP to the coordinator. If the coordinator receives NLOS RSP from mobile node within a timer given by a parameter LINKTIMEOUT, then continue the resume communication otherwise the coordinator assume that the link is broken.

If we consider the link recovery in cooperative communication for the unstable link, the delay time can be extended as a multi-hop link. In direct communication, MAC layer supported retry process for every packet frame, but this is strictly depended on value of macMaxFrameRetries. So with the difference of scenario, none of this value will be the best value. Cooperative communication is one of solution for controlling the reservation time of direct link dynamically. As mention in the introduction, the cooperative link recovery is applied for reservation

resource application which strictly QoS guarantee support. IEEE 802.15.7 defined three topologies for short-range wireless optical communication using visible light: peer-to-peer topology, star topology and broadcast topology. The QoS issue is only supported in GTS function of start topology.

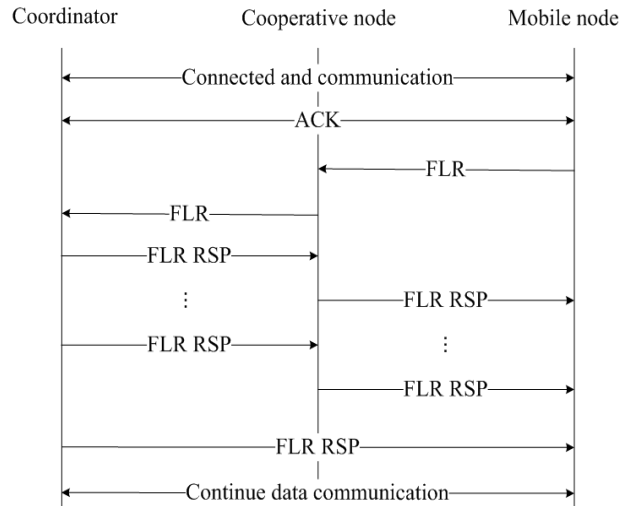

Fig. 3. Link recovery scheme using Cooperative communication from client

The structure of superframe is presented in Figure 4. The bandwidth allocation for new request bases on the remaining slots from the Contention Free Period. Among 16 Time-Slots of superframe, the Contention Free Period is limited by one slot for network beacon and some slots for Contention Access Period. The number of slots in CAP can be controlled by the PAN coordinator. In CAP, nodes which need resources will send requests to the coordinator. Upon receiving these requests, the coordinator will check whether there are sufficient available Time-Slots in the superframe for this request or not. If the number of available Time-Slots in the superframe is smaller than the number of requested, the GTS allocation request will be rejected; otherwise it is accepted. If the GTS allocation request is accepted, the admitted node must keep track of beacon frames for checking which Time-Slots have been allocated in the current superframe.

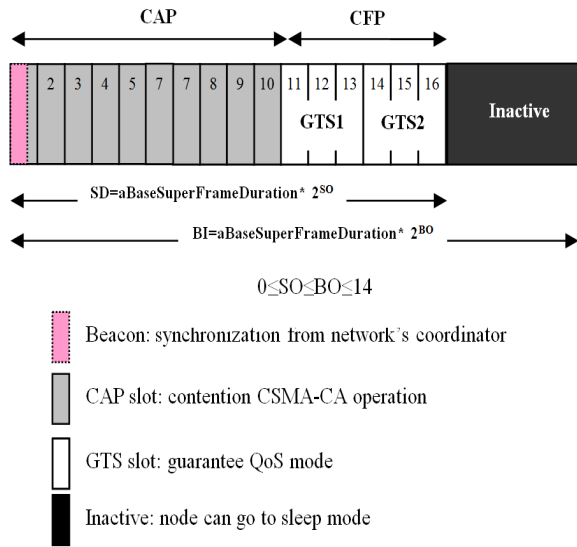

Fig. 4. IEEE 802.15.7 superframe structure

### III. Performance evaluation

First of all, we overview the GTS operation of IEEE 802.15.7 specification. The data packet process is presented as Figure 5. Node that has allocated a GTS must complete all transmission before the end of the GTS including data transmission, the Intra-Frame Spacing (IFS) and the acknowledgement. Otherwise, it must wait until the next GTS. A given GTS allocation may impose a restriction on the frame length. Moreover, only a part of the GTS can be used for data transmission. The rest will be idle or used by a potential acknowledgement frame. The transmission of an acknowledgement frame commences aTurnaroundTime symbols after the reception of the data frame. This allows the device enough time to switch between transmit and receive, or vice versa. To allow the received data to be processed, the acknowledgement frame is followed by a minimum inter frame separation period (IFS). The length of the IFS period is dependent on the frame size.

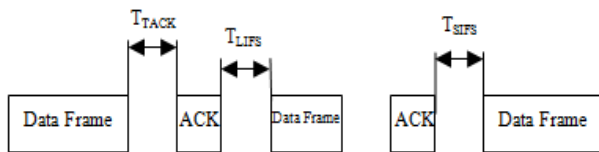

Fig. 5. Data transmission

A device that sends a data or MAC command frame with its Acknowledgment Request subfield set to one

shall wait for at most macAckWaitDuration optical clocks for the corresponding acknowledgment frame to be received. If an acknowledgment frame is received within macAckWaitDuration optical clocks and contains the same DSN (data sequence number) as the original transmission, the transmission is considered successful, and no further action regarding retransmission shall be taken by the device. If an acknowledgment is not received within macAckWaitDuration optical clocks or an acknowledgment is received containing a DSN that was not the same as the original transmission, the device shall conclude that the single transmission attempt has failed. The retransmission process is presented in Fig. 6.

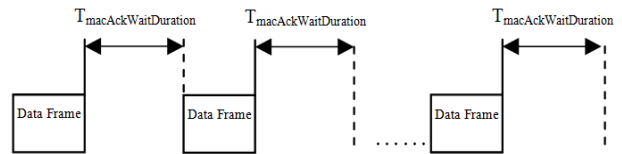

Fig. 6. Data retransmission flowchart

The value of macAckWaitDuration is presented by following equation:

$$\text{macAckWaitDuration} = \text{backoffperiod} + \text{aTurnaroundTime-RX-TX} + \text{clock period} \times \text{numSymAckFrame}$$

where:

$$+ \text{aUnitBackoffPeriod} = 20 \text{ symbol}$$

$$+ \text{aTurnaroundTime-RX-TX PHY I: 240 optical clock cycles, PHY II, III: 5120 optical clock cycles} + \text{clock period is presented in table I.}$$

$$+ \text{numSymAckFrame 103bit for PHY I and II and 111bits for PHY III.}$$

Table 1. IEEE 802.15.7 PHY

OOK	Manchester	5kbps	8ms
OOK	Manchester	100kbps	0.02ms
VPM	4B6B	1.25Mbps	4.8 μs
VPM	4B6B	2Mbps	3.75 μs
VPM	4B6B	5Mbps	0.3 μs
OOK	4B6B	12Mbps	0.125 μs
OOK	4B6B	96Mbps	0.05625 μs

From data transmission in Figure 6, we have the throughput performance of IEEE 802.15.7 standard as Figure 7.

To evaluate the performance of our scheme, we analyses one link recovery scenario as Figure 8 and configuration of VLC system as Table II.

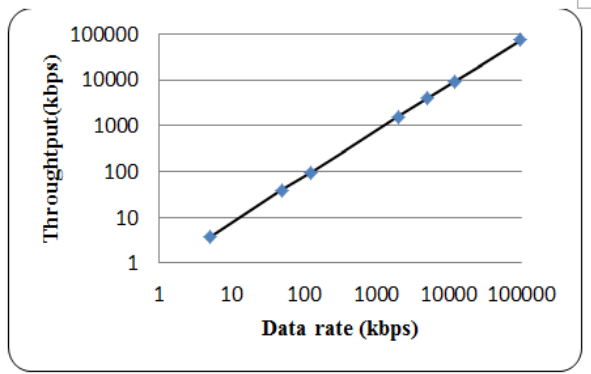

Fig. 7. IEEE 802.15.7 throughput

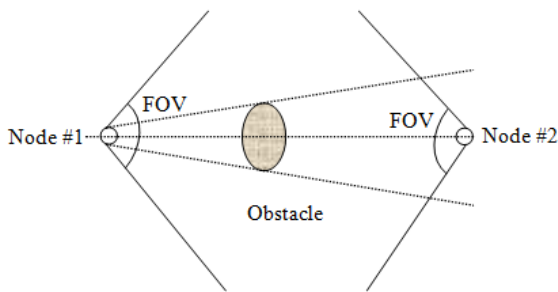

Fig. 8. Link recovery Scenario

Table 2. System configuration

Parameter	Value
FOV	120
d (distance between sender and receiver)	3m
S (Obstacle area)	0.5m x 1.7m
Data rate	2Mbps
Speed	0.1m - 5 m/s
macBeaconOrder	4
Superframe Order	4
macMaxFrameRetries	1-7
GTS bandwidth requirement	200kbps
Superframe duration	92100 $\mu$ s
Slot duration	57600 $\mu$ s
Slot bandwidth	96.125 kbps

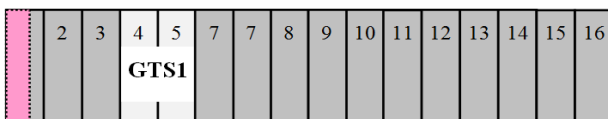

Fig. 9. GTS configuration

In this scenario, the obstacle is moving through the link between LED transmitter and PD receiver. And connection link is based on VLC LOS. Two devices communicate together on GTS mode with bandwidth requirement parameters on the Table II. The GTS resource allocation is shown in Figure 9.

The main idea of link recovery is to remain the connection allocated resources. When the link is

suddenly broken (the sender or receiver cannot reply from participate) the sender or receiver must broadcast link recovery request and wait the reply to ensure the connection. All researches for link recovery are tried to send the “link recovery request packet” and reply “link recovery reply packet” as soon as possible. By using cooperative communication, our scheme showed more advantage in controlling the recovered waiting time. The measurement comparison between direct communication and cooperative communication is presented in Figure 10. The link recovery requests are transit through a cooperative node to the participant node, it makes increasing the success probability of link recovery packet. In Figure 11, we can see the retransmission time requirement of different value of macMaxFrameRetries and the minimum time necessary for recovering the link when one obstacle moving with speed  $v$  through the LOS connection. From the calculation, we can see that if we want to recover the connection link by controlling the value of retransmission in MAC sub-layer, it will be very complex to configure this value.

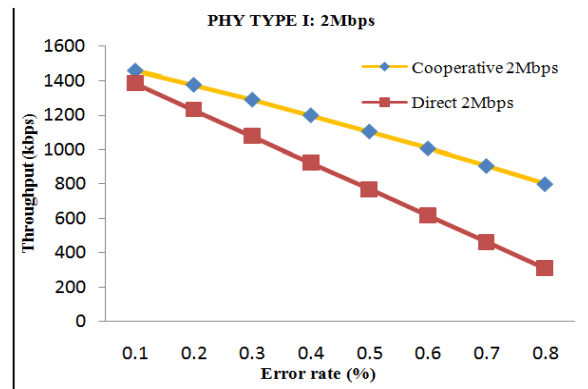

Fig. 10. Direct and cooperative communication

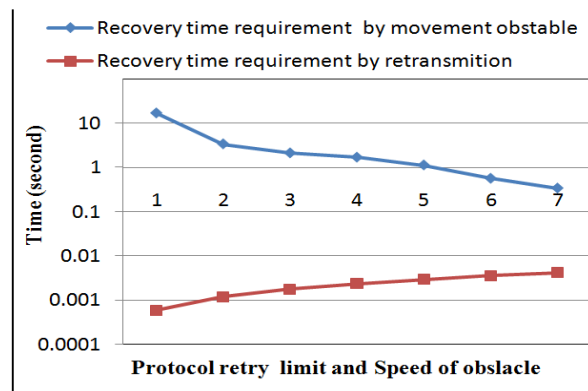

Fig. 11. Link recovery time restriction

## V. Conclusion

The line of sight and hidden terminal problem are the very critical and current research trend for standardization. These two problems affect the performance of the visible light communication. This paper presents mechanisms to support fast and energy efficient link recovery using cooperative communication.

## References

- [1] IEEE Standard for local and metropolitan area networks, "Part 15.7: Short-Range wireless optical communication using visible light," 6 september 2011.
- [2] P.Liu, Z.Tao and S. Panwar, "A cooperative MAC protocol for wireless local Area Networks," IEEE Internaional Conference on Communication 2005.
- [3] P. Liu, Z. Tao, S.Narayaman, T. Korakis and S.S. Panwar, "CoopMAC: A Cooperative MAC Protocol for WLANs," IEEE Journal on Selected Areas in Communication, vol. 25, no.2, February 2007.
- [4] David Tung Chong Wong, Chen Khong Tham, "Burst Mode Cooperative MAC Protocol in Ad Hoc Wireless Network," Communication Systems 2008 ICCS 2008, pp 1275-1279, Nov 2008, Singapore.
- [5] Y. Tanaka, T. Komine, S. Haruyama and M. Nakagawa, "Indoor Visible Light Data Transmission System Utilizing White LED Lights," IEICE Trans. Communication, vol. E86-B, pp.2440-2454, 2003.
- [6] Woo-Chan Kim, Chi-Sung Bae, Soo-Yong Jeon, Sung-Yeop Pyun, and Dong-Ho Cho, "Efficient resource allocation for rapid link recovery and visibility in Visible-light local area networks", IEEE Transactions on Consumer Electronics, Vol.56, No.2, May 2010.
- [7] Ying Li and Sridhar Rajagopal, "Fast and Energy-Efficient Link Recovery in Visible Light Communications," Consumer Communications and Networking Conference (CCNC), 2010 7th IEEE. Pp: 1-2, Feb 2010.
- [8] Le Nam-Tuan, Choi Sunwoong, Jang Yeong

Min, "Cooperative MAC protocol for LED-ID systems," ICT Convergence (ICTC) 2011, pp 144-150, Nov 2011.

### Nam-Tuan Le

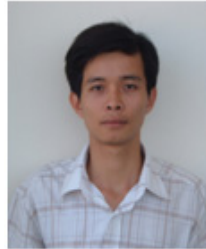

received the diploma in Faculty of information and communication Technology from HaNoi University of Science and Technology, Viet Nam in 2005. He completed his MS in Electronics Engineering from Kookmin University, Korea in 2011. Currently he is continuing his Ph.D. studies in Kookmin University. His research interests are sensor networks (MAC protocol), performance evaluation, resource management and visible light communication.

### Sunwoong Choi



received the B.S., M.S. and Ph.D. degree in Electrical Engineering and Computer Engineering from Seoul National University, Korea, in 1998 and 2000, and 2005, respectively. He worked for Samsung Electronics between 2005 and 2007. Since 2007, he is with the School of Electrical Engineering, Kookmin University, Korea. His research interests include MAC and routing protocols for wireless networks, network resource management, and future internet.

### Yeong Min Jang



received the B.E. and M.E. degree in Electronics Engineering from Kyungpook National University, Korea, in 1985 and 1987, respectively. He received the doctoral degree in Computer Science from the University of Massachusetts, USA, in 1999. He worked for ETRI between 1987 and 2000. Since Sept. 2002, he is with the School of Electrical Engineering, Kookmin University, Korea. His research interests are radio resource management, LED-ID networks, and multi screen convergence networks.