

# 무선 디지털청진기를 이용한 동물 진단시스템

박기영<sup>°</sup>, 홍수미<sup>\*</sup>, 이종하<sup>\*\*</sup>, 박진호<sup>\*\*\*</sup>, 정의붕<sup>\*\*\*\*</sup>

## Animal Diagnosis System Using Wireless Digital Stethoscope

Kee-Young Park<sup>°</sup>, Soo-mi Hong<sup>\*</sup>, Jong-ha Lee<sup>\*\*</sup>, Jin-ho Park<sup>\*\*\*</sup>, Eui-bung Jung<sup>\*\*\*\*</sup>

### 요약

동물 의료는 병의 정도나 치료의 필요성에 관계없이 보호자의 의향이 앞서는 어려운 의료행위이다. 특히, 동물 치료 중 심장 질환은 필요한 치료법의 결정이나 치료 효과의 확인에 대해서 동물 환자로부터 직접적인 답을 얻기가 어렵다. 그래서 동물 환자의 경우, 심장질환은 증상의 악화로 급변하거나 돌연사 등의 응급사태를 예측하고 그것에 대처하는 것은 거의 불가능하다.

심장 및 몸 안의 질환을 확인하는 1차 진단 방법은 청진이다. CT나 X-ray, 초음파 등의 최첨단 영상장비들을 이용하여 정확하게 측정할 수 있지만 장비가 비싸고, 이를 활용할 수 있는 전문인력이 요구되는 등 경제성으로 인해 2차 진단장비로 활용되어질 뿐 1차 진단을 위한 가장 좋은 진단도구로 여전히 청진기가 이용되어지고 있다.

본 논문에서는 수의사가 귀에 대지 않고 청진음을 분석하고 무선으로 어디서나 진단 할 수 있는 무선디지털 진단시스템에 대해 자세하게 서술하고, 이 시스템을 통해 진단되는 청진음에 대한 레벨교차율(LCR)과 에너지레벨을 통해 질병의 관계에 대해 새로운 개념의 진단시스템 환경을 제시한다.

**Key Words** : Animal Diagnosis System, Wireless Digital Stethoscope, LCR(Level Crossing Rate), Heart Sound, Lung Sound

### ABSTRACT

Medical treatment for animals is very difficult as the opinions of pets' masters take priority over treatment regardless of the seriousness of pets' disease or the needs of medical treatment. In case that a pet has heart disease, especially, it is difficult to get the direct answer from the pet's master on the decision or confirmation of treatment. For those reasons, it is almost impossible to predict and treat the pet before an emergency like the heart failure or an unexpected death happens. Using stethoscope can be the first diagnosis method to check the heart or any kinds of disease inside the body. High-tech equipments like CT, X-ray or Ultrasound can be used, but they can only be used as a second choice of diagnosis method since it requires professional skills and its high price. That's why stethoscope is still the best diagnostic tool when one makes the first diagnosis.

In this study, we give a detailed account of digital diagnosis system in which veterinarians can analyze the sound from stethoscope without bringing it to their ears and make a diagnosis wherever they are.

And we suggest a new concept of diagnosis system surrounding, which shows the relativeness of disease through Level Crossing Rate(LCR) and energy level from the stethoscope sound made in this system.

° 주저자 겸 교신저자 : 전주비전대학교 디지털전자정보과, kypark@jvision.ac.kr, 정회원

\* 전주비전대학교 보건행정학과, smhong@jvision.ac.kr,

\*\* 전주비전대학교 디지털전자정보과, jhlee@jvision.ac.kr, 정회원

\*\*\* 전북대학교 수의내과과, jpark@jbnu.ac.kr

\*\*\*\* 호원대학교 자동차기계공학과, bung4524@hanmail.net, 정회원

논문번호 : KICS2013-07-279, 접수일자 : 2013년 7월 3일, 최종논문접수일자 : 2013년 7월 24일

## I. Introduction

Stethoscope has been used to hear the heart and lung sound for people. Also, hearing of animal heart and lung sounds has been used by stethoscope too. Animal can not be diagnosed by his own and can be diagnosed in accordance with his owner only. Therefore, it is necessary to build equipment consists of new idea and concept of stethoscope modules that are suited for short range data transfer purposes. In this paper, we'd like to show useful data for evaluating the chest sound by applying LCR(Level Crossing Rate) to breathing sound data using wireless digital stethoscope system. We found that patient peak frequency and LCR value of spectrum revealed the significant difference regarding the disease<sup>[3]</sup>.

## II. Hardware Configuration

The transmitter block diagram of wireless digital stethoscope is shown in Fig. 1. While this system has been designed to make hardware very simple, it needs to be enforced on the operating software. This means that by re-programming the devices, many types of data logging can be achieved. Alternatively, it could be programmed to transmit a data only if a pre-determined level.

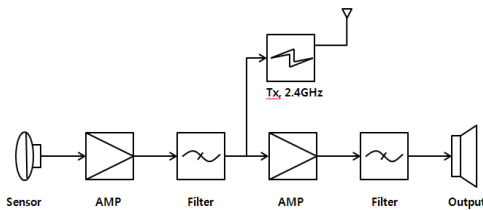

Fig. 1. Transmitter Block Diagram of Wireless Digital Stethoscope

Heart and lung sounds of animal are acquired on the chest by air-coupled header. Header consists condenser and dynamic microphone. In other words, header will be adapted with various sound collectors. The header is shown in Fig. 2.

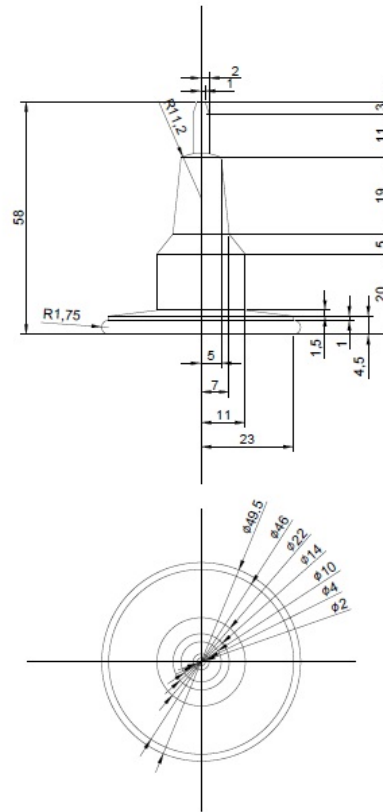

Fig. 2. Header Block Diagram of Wireless Digital Stethoscope

The microphone signals are pre-amplified and low pass filtered(3rd order 2000Hz) and then sent to the input interface which includes, automatic gain control, sample and holder and analog to digital converter. And a sequence generates the required control signals from a digitally controlled clock. The codec functionality of the DPU(Digital Process Unit) is extended by additional interfaces and allowing all kinds of digital audio processing systems to be connected to the USB.

The system is based on a personal computer with a data acquisition boards. The board has one channel analog inputs which are sequentially digitalized with 12 bits resolution during the sampling period. The digitalized signals are transferred from USB ports to the PC memory and finally stored on the hard disk. Also, single 3.6(V) lithium cell is used to power the unit. Thus, completely independent in use and suffers no external interference from other equipment.

The receiver block diagram is shown in Fig. 3.

The radio receiver monitors all the activity on the specific radio channel to which it is tuned and converts the presence or absence of the radio frequency carrier to the logic high or low respectively. This signal is monitored by the microprocessor which determines the validity of the data stream. This signal is converted by a line driver and transfer it to the PC via a USB port. Power is supplied to the receiver via a standard mains power adapter, the output of which is regulated within the receiver to 5(V), and LED was used to show the status of the power. The modulation of the radio frequency channel is performed entirely by the microprocessor in real time.

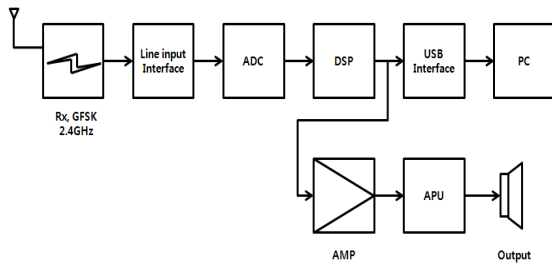

Fig. 3. Receiver Block Diagram of Wireless Digital Stethoscope

### III. Data extraction process

The following procedure was used to calculate the average level crossing rate energy. First, the microphone was calibrated independently from the system by using an audio analyzer. Their frequency bandwidth was flat from 20 to 2KHz by cut off frequency  $\pm 3\text{dB}$ . The analog module was calibrated by applying a 1mV sinusoidal signal to the inputs of all microphone pre-amplifiers and by storing the corresponding A/D output values for 10 gain levels. And the transfer function was approximated by a linear feedback of these values. The feedback coefficients and the microphone sensitivity of each input were saved in a memory file. During the data acquisition, each heart and lung sounds data is calculated by an average LCR.

In this paper, it is suggested that LCR algorithm is a versatile technique and has been used widely in

signal processing. It is of particular interest in biomedical signal sounds processing, because it can be used to calculate spectral correlation. And, this section is devoted to a description of the LCR. Usually one pitch period of a heart and lung sounds waveform is used as the unit in speech synthesis by the editing of speech elements. Especially level cross processing is explained here because it is the simplest case. In this system, one pitch period of biomedical signal sounds waveform is stored as a signal element in the form of level cross interval sequence. Therefore, level crossing rate is

$$L_n = \sum_{m=0}^{N-1} |\text{sgn}[x(n-m) - L_{th}] - \text{sgn}[x(n-m-1) - L_{th}]| \quad (1)$$

And average level crossing rate is

$$AVRLCR = \sum_{n=0}^{N-1} [L(n) / \text{length}]$$

In addition to these representations for each length, elements representing transitional parts between lengths are necessary. These transitional elements are generated by various combinations of the first and second formants. Each of these elements is represented by level cross sequences, on the average, and every interval of level cross has been quantized by 12 bits.

### IV. Software



Fig. 4. Software Block Diagram

A block diagram of the Software is shown in Fig. 4. A biomedical diagnosis algorithm is installed in the computer. And, the biomedical signals are received through the USB transmission path terminal. Then, the biomedical signals are analyzed using a predetermined biomedical signal analysis algorithm included in a fast fourier transformation and a logarithmic energy and level crossing rate

calculation, and are displayed on a monitor.

All of the numerical values and operational states of the program are displayed on the monitor.

In order to extract the characteristics of animal heart and lung sound signals, acoustic parameters are required for the analysis of signals. And the heart and lung sound signals have information of animal disease on the time based. So the digitization of the animal sounds data is required in order to overcome the limitation of hardware resource. Also, the lossless compression of the heart and lung sound information is required.

The logarithmic energy level crossing rate is calculated by the logarithmic energy level crossing rate calculation by using Equation (1).

In case that  $L_n$  is a threshold value, it is determined by the characteristic of the input signal and various examination results. Since the determination of the threshold value and a large amount of calculation are problems, it is assumed that the value of  $L_n$  is not always constant, and the value of  $L_n$  is determined by observing variation in the characteristics of the input signal and using the average characteristic of the input signal. That is, the threshold value is determined by input variables. Accordingly, the threshold value which is experimentally used for the detection of signals is fixed, so that a threshold value that varies depending on the situation is determined, a biomedical signal interval is detected by performing FFT on sound data and using the sum of energies of 20Hz~2kHz, the LCR and whether energy level continues to increase.

As a result, auscultation of a animal's disease and condition is determined by the subjective comments based on the hearing ability of a physician. The disadvantages of traditional analog stethoscopes should be overcome. However, thanks to visual confirmation and determination, it is possible to perform an objective medical diagnosis.

### V. Results and Discussion

The 5 recordings were performed by each disease with an acquisition time of 1 minute 5 position(left,

right, center lung and back left and right below) and a sampling rate of 2KHz per input at Animal Medical Center in Chunbuk National University. Digit number of data sample of a biomedical signal sound is 40,000 in this paper and training set is 5 per name of disease. And block diagram of data acquisition is illustrated in Fig. 3. And Fig. 4. is shows animal diagnosis analysis software. Bio sound data has collected to use analysis software by making visual C++.

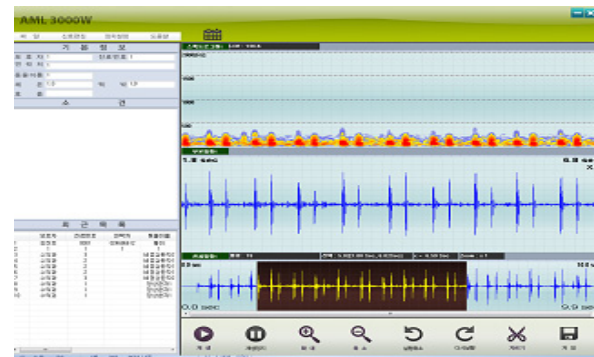

(a)

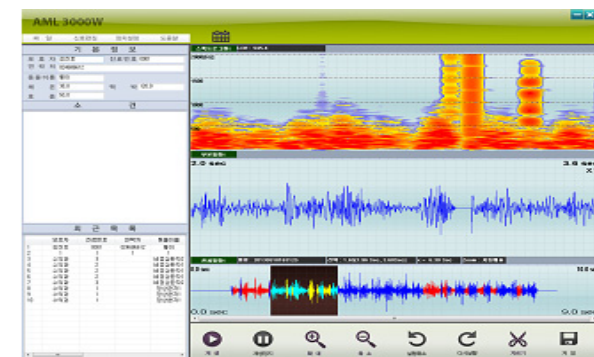

(b)

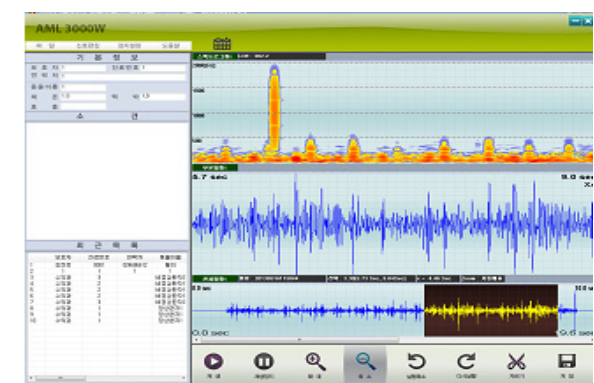

(c)

Fig. 5. Normal(a) & Abnormal Wave Form(b,c)

Fig. 5 is shows waveform of the normal and

abnormal heart sound of an animal(dog). The normal waveform is regular(LCR=115.5 points(a)) and spectrogram of energy is very low frequency under 300(Hz), on the other hand, abnormal(LCR=479.3 (b), LCR=365.0 points(c)) waveform is similar to noise and amplitude of heart sound is high. Also it is showed the spectrogram of energy is very high.

Therefore, we could distinguish between normal and abnormal case using level crossing rate(LCR) and spectrogram of energy rate.

Fig. 6. is shows the diagnosis animal with wireless digital stethoscope.



Fig. 6. Diagnosis animal with wireless digital stethoscope

## VI. Conclusion

In the experiment for heart and lung sounds, the animal diagnosis system using wireless digital stethoscope and design with programming are introduced. This paper proposed characteristic heart sound to use average LCR and spectrogram of energy rate by using hardware & software system. Especially, wireless stethoscope on the type of adapting header (Fig. 2) is confirmed to measure better heart and lung sounds.

Fig. 5 is shows various data for each disease which are detected as the useful heart sound data in diagnosis.

Considering the above results, it is necessary to

study for more accurate hardware structure and software to process hear and lung sound of the system.

Also more reference DB for solving the reliable heart and lung sound algorithm have to be designed for a perfect hardware system. We are going to analyze the constraint conditions of the software for more useful design. Also, The hardware is scheduled to be manufactured as ASIC system after developing working model available for new heart and lung sound algorithm and its hardware system.

## Reference

- [1] D. W. Cugell, "Lung Sound Nomenclature," *Amer. Review Respiratory Disease*, vol. 136, no. 4, pp. 10-16, Oct. 1987.
- [2] R. Loudon and P. L. H. Murphy, "Lung sounds," *Amer. Review Respiratory Disease*, vol. 130, no. 4, pp. 663-673, Oct. 1984.
- [3] K. Y. Park, "Wireless diagnosis system for chest disease using thoracic sound," *IEEE Honam Section*, vol. 13, no. 1, pp. 57-62, Jeonju, Korea, June 2004.
- [4] M. H. Beers and R. Berkow, *The Merck Manual of diagnosis and therapy*, Merck Research Laboratories Division of Merck & Co. INC Whitehouse Station, 2000.

박기영 (Kee-young Park)



2002년 2월 전북대학교 전자공학 공학박사

1982년~현재 전주비전대학교 디지털전자정보과 교수

2004년~현재 썬메디텍(주)대표이사

<관심분야> 신호처리 및 시스

템(음성), Bio processor

홍 수 미 (Soo-mi Hong)



2003년 5월 Purdue University  
보건과학 졸업  
2008년 2월~현재 전주대학교  
영어영문학과 TESOL석사  
2012년 3월~현재 전주비전대  
학교 보건행정학과 교수

이 종 하 (Jong-ha Lee)



1982년 2월 전북대학교 전기  
공학과 졸업  
1984년 2월 전북대학교 전자  
계산기 공학석사  
1993년 8월 전북대학교 전자  
공학과 공학박사  
1990년 3월~현재 전주비전

대학교 디지털전자정보과 교수

<관심분야> 디지털신호처리, OLED TV1

박 진 호 (Jin-ho Park)



1994년 2월 전북대학교 수의  
과 대학졸업 학사  
1996년 2월 전북대학교 수의  
내과학졸업 석사  
1999년 8월 전북대학교 수의  
내과학졸업 박사

정 의 봉 (Eui-bung Jung)



1992년 건국대학교 대학원 전  
자공학과 공학박사  
1992년 호원대학교 자동차기계  
공학과 교수  
2005년~현재 전주정보영상산  
업진흥원 이사  
2005년~현재 원대학교 산학

협력단장

2012년~현재 한국통신학회 전북지부장